

Instruction Manual

AD8000 Series

Spectrum Analyzer

Safety Requirement

Safety Level

This manual has the following conversions for presenting information.

WARNING: A warning marker alerts you any harmful matters that users should pay attention to the operation method. Users must not do any operation or process before the condition of this marker is met, otherwise it might cause personal injury.

CAUTION: A caution alerts you to any danger matters that users should pay attention to the operation method. Users must not do any operation or process before the condition of this marker is met, otherwise it might damage the device.

Before connecting to the power switch, please make sure that the voltage and currency of external AC-DC power supply or the cigarette lighter meet the equipment requirements, otherwise it might damage the device or adaptor.

Since there are multiple circuit joints in the device, and touching might cause personal injuries and device damages, only trained maintenance personnel could remove the case and maintain the device.

Warranty

This instrument is guaranteed for a period of 12 months from the date of selling. The producer or distributors have the responsibility of necessary calibration and test. The device could be packed and sent back to users only after the test is pass.

Users must use and check the instrument according to the manual. If maintenance is needed, please send back to our company our authorized maintenance stations.

Generally, in the warranty period all faults which are not caused by improper use would be repaired by our company free. Users need to pay for the freight and insurance to send the product back. The freight sending the product back to users would pay by our company or authorized maintenance stations.

The device would execute the programming command after installing all software and hardware correctly. But we do not guarantee the operation continuity and absence of faults.

The guarantee is limited only to the instrument and does not involve any damage of equipment, personnel and property caused by improper use of the instrument.

Limitation

The warranty is not applicable for the faults resulted by improper use or inadequate maintenance (including software or interface), and unauthorized open of the instrument. Within the 12-month warranty period, calibration, maintenance service and consultation shall be free. After the 12 months warranty period, fees for material and repair workman will be charged appropriately. The battery is not included in the range of warranty since it is consumable.

The following items are not under warranty:

- ① Damage caused by improper voltage or AC/DC currency input.
- ② Deformation or damage of panel, switches, devices and case as well as defects involving interval parts caused by external mechanical force (shocking and dropping, etc.).
- ③ Defects caused by unauthorized repair.
- ④ When users pick up the device, please check it on the nail. If there is any damage, please contact with the transport company. Only receivers (the person and department of receiving the product) has the right to ask for compensation for the transportation damages.
- ⑤ Defects caused by the instrument worked beyond the required technology specification.

All specifications and operations might change that we would not inform individually. For any other needs, please ask our company.

Our company has all the copy rights. No copy, edition or translation are allowed without written approval.

Contents

1	General Information	1
1.1	Main Functions	2
1.2	Preventive Maintenance	2
1.3	Annual Inspection & Calibration	3
1.4	Protection of ESD.....	3
1.5	Battery Replacement.....	3
1.6	Carrying Bag.....	4
2	Device Overview	6
2.1	Turning on the Instrument	7
2.1.1	Front Panel Overview	8
2.1.2	Measurement Panel Introduction	11
2.2	UI Overview	13
2.2.1	Screen Information	13
2.2.2	Menu Operation	14
2.2.3	Symbols and Indicators.....	15
2.2.4	Data Entry	16
2.3	Mode Selector Menu.....	17
2.4	Menu Trees.....	18
2.4.1	AMPTD key.....	18
2.4.2	CPL key	20
2.4.3	FREQ key	21
2.4.4	MARK Key	23
2.4.5	MEAS key	25
2.4.6	MEAS SETUP key	26
2.4.7	PEAK key	27
2.4.8	SAVE key	29
2.4.9	SYS key	30
3	Spectrum Measurement	32
3.1	Selecting Measurement Type	34
3.2	Function & Using of Swept SA	35

3.2.1	Basic measurement	35
3.2.2	Basic Parameters Settings.....	52
3.2.3	Measurement Parameter Settings	65
3.2.4	Basic Usages.....	68
3.3	Channel Power	80
3.3.1	Basic Measurement	81
3.3.2	Basic Parameter Settings	87
3.3.3	Measurement Parameter Setting.....	88
3.3.4	Basic Usage	91
3.3.5	Slot Signal Basic Parameters Settings.....	92
3.3.6	Slot Signal Measurement Setting	93
3.4	Adjacent Channel Power.....	95
3.4.1	Basic Measurement	96
3.4.2	Basic Parameter Settings	97
3.4.3	Measurement Parameter Settings	98
3.4.4	Basic Usage	101
3.5	Occupied BW	103
3.5.1	Basic Measurement	104
3.5.2	Basic Parameter Setting.....	106
3.5.3	Measurement Parameters Settings.....	107
3.5.4	Basic Usage	110
3.6	Field strength.....	112
3.7	FM/AM	114
3.8	Harmonic Analysis	116
4	Interference Analysis	117
4.1	Spectrogram	118
4.2	Signal Strength.....	120
4.3	Received Signal Strength Indicator (RSSI)	121
4.4	Channel Sweep	123
4.5	Interference localization.....	124
4.6	Difference Spectrum	125

4.7	Signal ID	126
5	Base Station Test.....	127
5.1	TDD-LTE	128
5.1.1	Power vs. RB.....	129
5.1.2	Constellation	131
5.1.3	Control CH Power.....	133
5.1.4	Summary	136
5.1.5	Scanner	136
5.1.6	Channel Power.....	140
5.1.7	Occupied Bandwidth.....	141
5.1.8	Power vs.Time.....	142
5.1.9	ACLR	144
5.1.10	Co-Channel Interference.....	145
5.1.11	Upstream Interference	146
5.2	FDD-LTE	147
5.2.1	Power vs RB	148
5.2.2	Constellation	150
5.2.3	Control CH Power.....	151
5.2.4	Summary	152
5.2.5	Scanner	152
5.2.6	Channel Power	153
5.2.7	Occupied Bandwidth.....	154
5.2.8	ACLR	155
5.2.9	Co-Channel Interference.....	156
5.2.10	SEM	157
6	Coverage Mapping	158
6.1	Indoor Coverage	159
6.1.1	Measurement Setting	160
6.1.2	Coverage Measurement	162
6.1.3	Save Measurement File	165
6.1.4	Open Coverage File.....	166
6.2	Outdoor Coverage	167
6.2.1	Coverage Measurement	168
6.2.2	Save File	170
6.2.3	Open File	172

7	Tracking Source	174
8	File Operation	176
8.1	Save File	177
8.2	File Management.....	180
9	Other Functions and Settings	182
9.1	System Calibration.....	185
9.2	Help Information	187
9.3	System Settings	188
9.3.1	Network	188
9.3.2	Language	190
9.3.3	Buzzer.....	191
9.3.4	GPS.....	192
9.3.5	Time	193
9.4	Software Update	194
10	Program Guide	195
10.1	SCPI Basis	196
10.1.1	Brief Introduction.....	196
10.1.2	Command Keywords & Syntax	196
10.1.3	Create Valid Command	197
10.1.4	Special Characters in Command	198
10.1.5	Parameters in Command.....	199
10.2	Control Method	201
10.2.1	Connection Method	201
10.2.2	PC Hardware Setting.....	204
10.3	Command Instruction.....	206
10.3.1	General Command	206
10.3.2	System Command	207
10.3.3	Spectrum Analysis Mode Command List	207
11	Appendix	219
11.1	Glossary explanation	219
11.2	Prompt Information List	221

11.3 Specifications.....	224
11.3.1 Frequency Index.....	224
11.3.2 Amplitude Index.....	225
11.3.3 Input/Output Index.....	229
11.3.4 Level Index.....	230
11.3.5 Other Index.....	230

1 General Information

This chapter would mainly introduce following items:

- Preparation before using
- Device & accessories
- ESD
- Technical support & service

1.1 Main Functions

The AD8000 is an integrated multi-functional analyzer that eliminates the need to carry and learn multi instrument. Except spectrum analysis function, the AD8000 is also configured functions including power measurement, occupied bandwidth measurement, interference analyzer, tracking generator and a high accuracy GPS receiver for location stamping.

The bright 6.5-inch color display provides visibility even in hard light. Built-in Li-Ion battery can work more than 3.5 hours.

The internal 1G flash memory is large enough to store approximately 2,000 traces or setup files. Measurements data and setup files can also be stored in a USB flash disk or transferred to PC via the LAN cable.

Workbench software is based on PC platform. It could generate measurement report, check and manage data and history data, and analyze cursors, limit line, measurement curve and etc.

This device is produced according to ISO9001 international quality management system standard by AD INSTRUMENTS. The ISO9001 quality system was registered and certificated in 1996.

1.2 Preventive Maintenance

AD8000 series preventive maintenance includes the unit surface cleaning, RF connectors and all accessories cleaning. Clean unit surface with a soft, lint-free cloth dampened with water.

<p>Caution: To avoid damaging the display or case; do not use solvents or abrasive cleaners.</p>

Clear the RF connectors and center pins with a cotton swab dampened with denatured alcohol. The fingers of the N(f) connectors and the pins of the N(m) connectors should be unbroken and uniform in appearance. If you are unsure whether the connectors are undamaged, gauge the connectors to confirm that the dimensions are correct. The test port cable should be uniform in appearance, and not stretched, kinked, dented, or broken.

1.3 Annual Inspection & Calibration

All branches and offices of AD INSTRUMENTS are responsible for the annual maintenance and calibration to ensure the proper use. It is suggested that users do the maintenance and calibration regularly.

1.4 Protection of ESD

AD8000 series, like other high performance instruments, is susceptible to electrostatic discharge (ESD) damage. Coaxial cables and antennas often build up a static charge, which may damage the AD8000 input circuitry. AD8000 operators must be aware of the potential for ESD damage and take all necessary precautions.

It is recommended to discharge the static by connecting a short or load device to the cable or antenna before connecting them to AD8000. It is important to remember that the operator may also carry a static charge that can cause damage. Following the practices outlined in the above standards will ensure a safe environment for both personnel and equipment.

1.5 Battery Replacement

The battery can be replaced without the use of any tool. The battery compartment is located on lower side of rear (when you are facing the measurement display). Wring out two screws, slide the cover down and remove the battery. Installation is the opposite of removal.

Note: Ensure the correct connection of battery joints and power lines, otherwise connection would fail.



Fig. 1-1 Battery Replacement

AD8000 Series Spectrum Analyzer Instruction

Before using the spectrum analyzer, the battery should be charged. AC/DC power adaptor and vehicle cigarette lighter 12VDC adaptor could be used.

NOTE: Use only batteries, adapters, and chargers provided with this instrument.

Warning: When using the Vehicle charger, Make sure that the supply is rated for a minimum of 60 Watts at 12 VDC, and the socket is clean without any dirt or debris. If the adapter plug becomes hot to the touch during charging, Please discontinue using immediately.

NOTE: AD INSTRUMENTS recommends removing the battery for long-term storage of the instrument.

1.6 Carrying Bag

The AD8000 can be operated in the soft carrying bag. On the back of the case there is a large storage pouch for accessories and power supply.

To install the instrument into the soft carrying case:

1. The front panel of the case is secured with hook-and-loop fasteners. Fully close the front panel of the case. When closed, the front panel supports the shape of the case while you are inserting the AD8000.
2. Place the soft carrying case face down on a stable surface, with the front panel fully closed and laying flat.
3. Open the bag from the top.
4. Put the device in considering the position of the device connector.
5. Put on the back cover.

AD8000 Series Spectrum Analyzer Instruction



Fig. 1-2 Carrying Bag

2 Device Overview

This chapter would introduce the general information of AD8000 series handheld spectrum analyzer for users.

Main content:

- Turning on the instrument
- Front Panel Overview
- Test Panel Connector Overview
- Display Overview
- Symbols and Indicators
- Data edition

2.1 Turning on the Instrument

The AD INSTRUMENTS AD8000 models are capable of approximately 3.5 hours of continuous operation with fully charged. It can also work while charging with AC/DC adapter or vehicle cigarette lighter.

Warning: When using vehicle cigarette lighter, make sure that the supply is rated for a minimum of 60 Watts at 12 VDC, and the socket is clean without any dirt or debris. If the adapter plug becomes hot to touch during charging, Please discontinue using it immediately.

Press the ON/OFF button on the front panel for 2 seconds to turn on the spectrum analyzer. Wait for about 10 seconds to enter the measurement interface to start measuring.

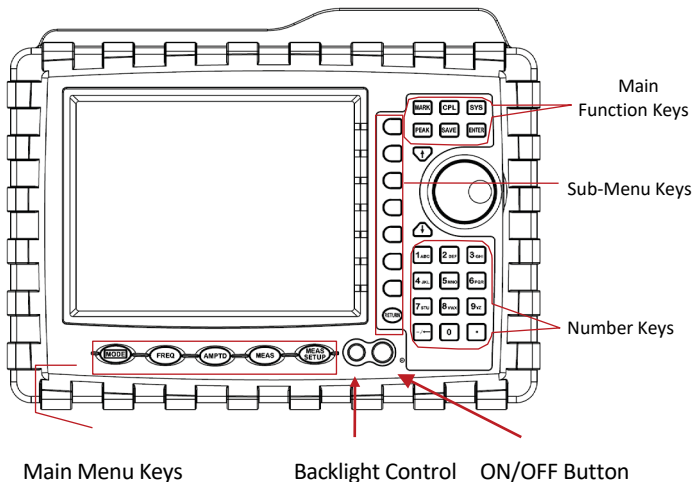

Fig. 2-1 Spectrum Analyzer Interface

2.1.1 Front Panel Overview

The AD8000 Series menu-driven interface is easy to use and requires little training. The five main menu keys below the screen and eight submenu keys on the right side are menu keys. Function keys on the right consist of six main function keys and twelve measurement function keys. There are 12 number keys, including number 0 to 9, +/- and '.' Key. There is also a knob for changing and selecting.

Note: the pop-up menu of some keys are the same in all circumstances, others might be different under different measurement mode and type. For details, please see 2.4.

1 Main Menu Keys

Five main menu keys are below the display screen.

MODE	Press the key, and then select a measurement mode by pressing the corresponding sub-menu key.
FREQ	active the frequency menu, set relevant parameter
AMP	active the amplitude menu, set relevant parameter
MEAS	active the measurement menu, select measurement type
MEAS SETUP	up measurement parameters for different measurement type

2 Sub-menu Keys

There are 8 sub-menu keys at the right of the screen shown as fig. 2-1. They could change the settings of the device with other keys.

3 Main Function Keys

There are 6 main function keys at the top of the key area at the right of the screen shown as fig. 2-1.

AD8000 Series Spectrum Analyzer Instruction

MARK	Mark: Active the mark measurement function to open and shut, reading and comparison of the frequency mark.
PEAK	Peak: Active the peak menu to do the operations such as opening, closing, reading, comparing the peak value and etc.
CPL	complex function key: set parameters such as RBW
SAVE	Save: active file menu, could do operations such as saving trace, image and status file, check and manage.
SYS	System: active system menu. It is used to set system parameters, display system information, complete system update and etc.
ENTER	Confirm: used to confirm editing parameters or current operation

4 '↑ ↓' Direction Keys

'↑ ↓' direction keys are at the center of the key area at the right of the screen. They are used to change the editing parameter or select item from the list. It is also used to move the marker.

5 Knob

The knob is at the center of the key area at the right of the screen, used for change the editing parameter or select item from the list. It is also used to move the marker. Pressing the knob has the same effect of pressing ENTER.

6 Number Keys

'0~9' number keys, '+/-' symbol keys, and '.' key are at the key area at the right of the screen, used to complete number editing

Detail operation of each key would be described in the following chapters.

7 LED Indicator Light

The operation indicator light is at the button of the key area at the right of the screen. Press the power button to turn on the device, and then the green light turns on.

8 Back Light Control Key

It is at the button right corner of the key area at the right of the screen. There are five levels of the lightness. It would level up with each press, and turn to the lowest level from the highest, and that circle repeats.

9 Power Switch

Press the power switch, and the power-off menu would pop up. Choose the operation such as power off and restart. Long press to switch the device off directly.

2.1.2 Measurement Panel Introduction

Figure 2-2 is the measurement panel of the spectrum analyzer.

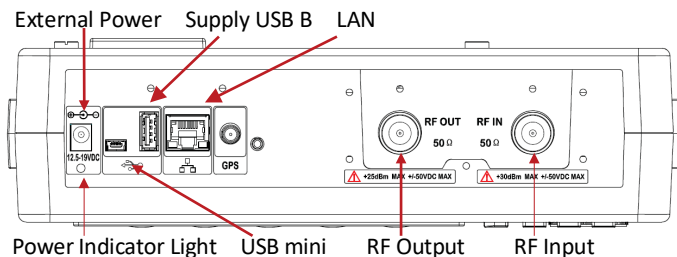

Fig. 2-2 Measurement Panel Connector

1 External Power Supply

The external power connector is used to supply power for the unit and charge the battery. Input voltage is 12V~19V, and power more than 60w. When it start to charge connecting to the AC-DC adaptor or vehicle cigarette lighter, the power indicator light turns to green. It turns to orange when fully charged.

Warning: only adaptors and chargers from AD INSTRUMENTS could be used. Make sure the power supply of 12VDC vehicle cigarette lighter is 60W@12VDC and dry when using. Please stop using immediately if the plug

2 USB Port – Type A

The AD8000 has a Type A USB connectors that accept USB flash memory devices for storing files such as measurement curves, setup data, and screen images.

3 USB Port - Mini B

Used for connecting with PC

AD8000 Series Spectrum Analyzer Instruction

4 LAN Port

10M/100M self adaption, the spectrum analyzer connect to PC through LAN port, used for workbench software communication. The included disk has workbench inside.

5 RF Input

50ΩN negative connector, max. input +30dBm, ±50VDC

6 RF Output / Reflection Input

50ΩN negative connector, used for reflection measurement, max. input +25dBm, ±50VDC

2.2 UI Overview

2.2.1 Screen Information

This section introduces the screen information while using the spectrum analyzer, with an example of figure 2-3 spectrum measurement type under spectrum analysis mode.

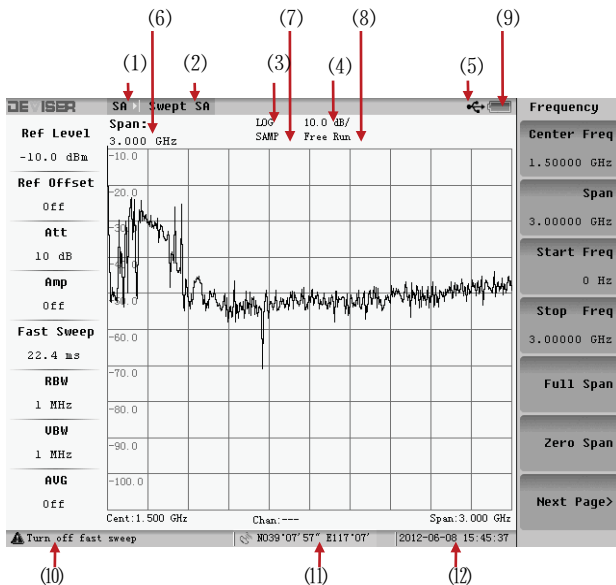

Fig. 2-3 Screen Information

- | | |
|------------------------|-----------------------|
| (1) Measurement mode | (2) Measurement type |
| (3) logarithmic/linear | (4) unit/scale |
| (5) USB | (6) Parameter Setting |
| (7) Detector Mode | (8) Trigger mode |
| (9) Battery Status | (10) Note information |
| (11) GPS Location | (12) Date & Time |

2.2.2 Menu Operation

There are 8 typical menus, and each is described below in detail.

1 Setting Parameters

Press the corresponding menu, and the parameter shows in the middle of the screen. Use the number keys, arrow keys or the knob to set the parameter, and press the Enter key to exit.

Example: Menu of 'Cent Freq'.

2 Enter the next submenu (without parameter)

Press the corresponding menu key to enter the next submenu. These menus are marked by '>'.
>

Example: Menu of 'Trace>'.

3 Enter the next submenu (with parameters)

Press the corresponding menu key to enter the next submenu to select an option, and then return to the previous menu automatically. These menus are marked by '>'.

Example: Menu of 'Detector Mode>'.

4 Active Dialog box

Press the corresponding menu key, and there would be a dialog box popped up. These menus are marked by '=>'.

Example: Menu of 'Limit=>'.

5 Implement the menu function

Press the menu key to implement the corresponding function.

Example: Menu of 'Single Sweep'.

6 Two functions switch (no parameter)

Press the corresponding menu button to switch the two functions.

Example: Menu of 'Log/Lin'.

7 Two functions switch (with parameters)

Press the corresponding menu button to switch the two functions, and then return to the previous menu automatically.

Example: Menu of 'Ref Offset'.

8 No operation



Some of the menus are available only if some conditions are fulfilled, otherwise it is gray showing that the menu is invalid.

Example: Menu of 'Normal Detector Mode' in the fast sweep mode is not available. It means under the fast sweep mode, there is no normal detector mode.

2.2.3 Symbols and Indicators

The following symbols and indicators indicate the instrument status or condition on the display.





1 Calibration status

- ◇ : Calibration status OFF;
- ◇ : Frequency response OFF

Single sweep

- ◇ : single sweep on

2 Battery Symbols

- ◇  Green: Battery is 30% to 100% charged;
- ◇  Yellow: Battery is 10% to 30% charged;
- ◇  Red: Battery is 0% to 10% charged;
- ◇  Bolt and Scroll Bar: Battery is being charged
- ◇ : No battery, only adapter is used

When either the AC-DC Adapter or the 12 VDC adapter is connected, the battery automatically receives a charge, and the battery symbol is displayed in bar, and the indicator light is green. It turns to orange when fully charged..

Caution: Use only use batteries, adapters, and chargers provided by AD INSTRUMENTS.

2.2.4 Data Entry

1 Parameters edition

You can set parameters with the number keys, arrow keys and the knob. It is simple to change the parameters quickly with the arrow keys. The change rule is 1, 3, 5 steps increasing or decreasing. Long pressing could change the parameter fast. You can change the parameter continuously with the knob with a changing rule of linear variation. They could reduce users' workload.

2 Press the corresponding submenu key to edit

When pressing the corresponding submenu key, parameter shows on the upper left corner of the display. You can set the parameter using the numeric keys, arrow keys or the rotary knob, and press Enter to exit the editor.

3 Text Entry

To save files and enter file name, number keys and character keys are needed. For instance, to enter '1aB':

- Press once '1abc' to entry the number '1';
- Press twice '1abc' to entry the number 'a';
- Press '.' once, and then press twice '1abc' to entry the number 'B';

2.3 Mode Selector Menu

Press the MODE key to enter the measurement mode selection menu (Fig. 2-4). You can select the desired measurement mode, or enter the next level menu.

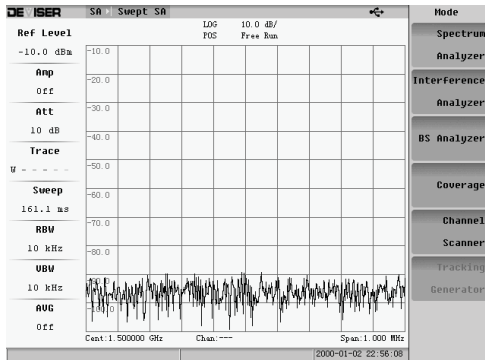

Fig. 2-4 Measurement Mode Selection Menu

2.4 Menu Trees

This part lists the menu trees that ordered by characters in detail. Some menus only can be activated in the instrument with corresponding options.

We would introduce in alphabetical order. Different function of the same key in different measurement mode/type would also be shown.

Note: We will list menus as far as possible. Because some measurements are option functions, some of instruments may be without some menus.

2.4.1 AMPTD key

The AMPTD key has different function in different measurement type. It has one function in spectrum mode swept SA and another in channel power, adjacent channel power and occupied bandwidth.

- Spectrum mode -> AMPTD menu in swept SA:

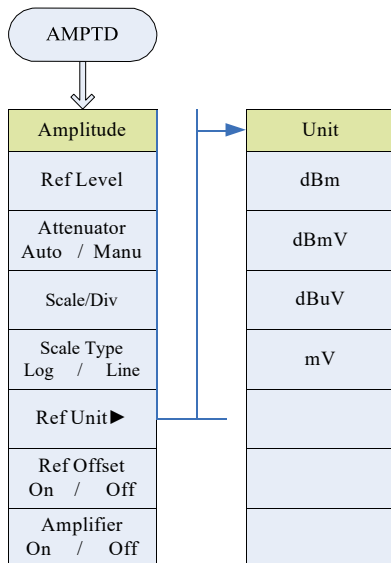

AD8000 Series Spectrum Analyzer Instruction

- Spectrum mode -> AMPTD menu inchannel power, adjacent channel power and occupied bandwidth

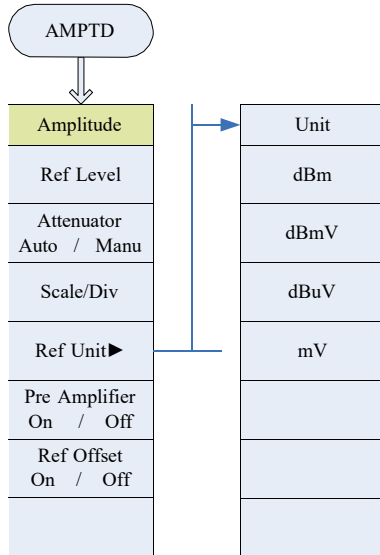

2.4.2 CPL key

The CPL key has the same menu in 4 different measurement modes: swept SA, channel power, adjacent channel power and occupied bandwidth.

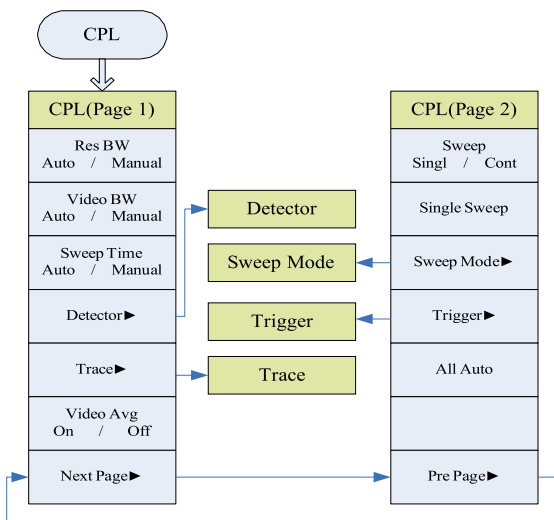

Detector
Sample
Posi-Peak
Neg-Peak
Normal
AVG

Trace
Trace 1 2 3
Clear Write
View
Blank
Max Hold
Min Hold

Trigger
Free Run
Video
Line

Sweep Mode
Fast
Performance
No FFT

2.4.3 FREQ key

The FREQ key has different function in different measurement type. It has one function in spectrum mode swept SA and another in channel power, adjacent channel power and occupied bandwidth.

- Spectrum mode -> FREQ menu in swept SA:

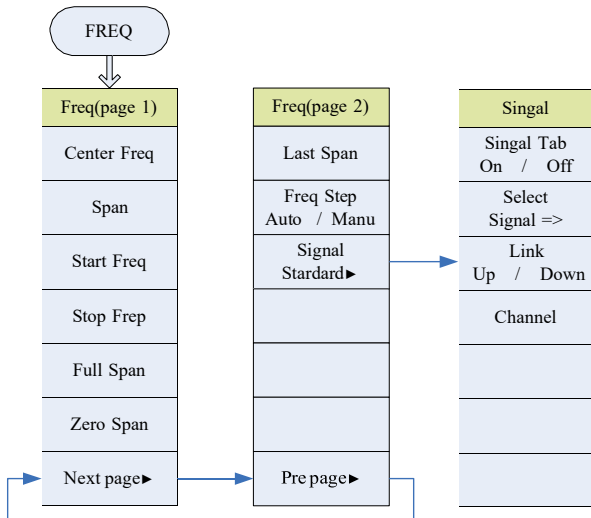

AD8000 Series Spectrum Analyzer Instruction

- Spectrum mode -> FREQ menu in channel power, adjacent channel power and occupied bandwidth

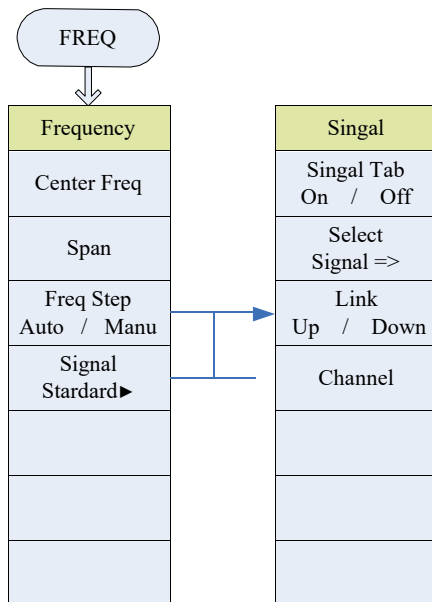

2.4.4 MARK Key

The MARK key has different function in different measurement type. It has one function in spectrum mode swept SA and another in channel power, adjacent channel power and occupied bandwidth.

- Spectrum mode -> MARK menu in swept SA:

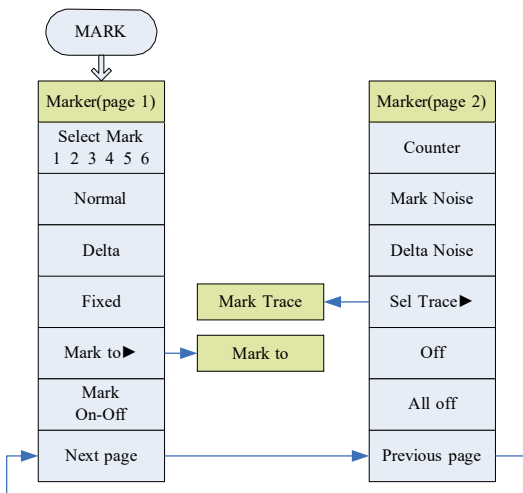

AD8000 Series Spectrum Analyzer Instruction

Marker to	Mark Trace
Mark to Ref Level	Auto
Mark to Cent Freq	1
	2
	3

- Spectrum mode -> MARK menu in channel power, adjacent channel power and occupied bandwidth



2.4.5 MEAS key

The MEAS key has different function in different measurement type. This device currently support spectrum analysis mode only.

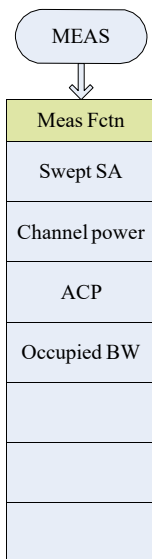

2.4.6 MEAS SETUP key

The MEAS SETUP key has different function in different measurement type. The functions are different in 4 modes.

- Spectrum mode ->MEAS/SETUP menu in swept SA
- Spectrum mode -> MEAS SETUP menu in channel power (upper left)
 - Spectrum mode -> MEAS SETUP menu in adjacent channel power (upper right)
- Spectrum mode -> MEAS SETUP menu in occupied bandwidth (below)

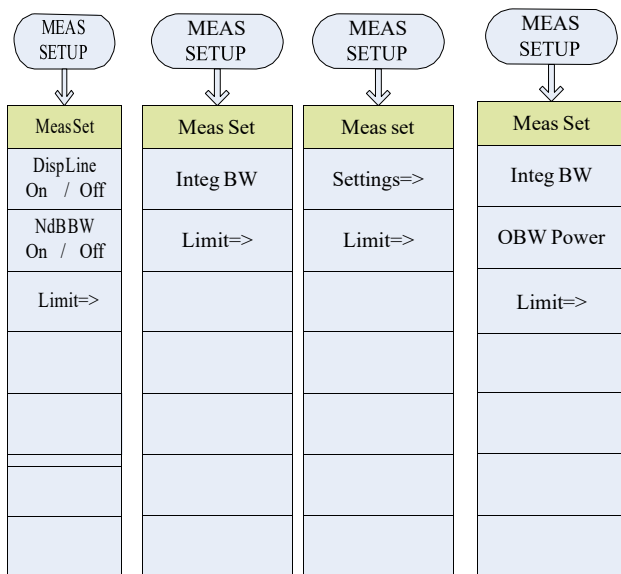

- Spectrum mode -> MEAS SETUP menu in field intensity

2.4.7 PEAK key

The PEAK key has different function in different measurement type. It has one function in spectrum mode swept SA and another in channel power, adjacent channel power and occupied bandwidth.

- Spectrum mode -> PEAK menu in swept SA:

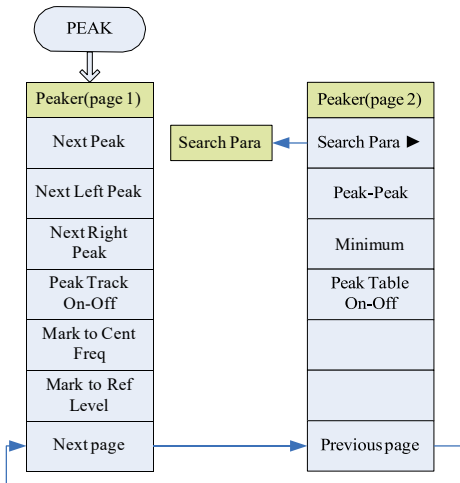

AD8000 Series Spectrum Analyzer Instruction

Search Para
Search Auto/Manual
Abs lev On-Off
Peak to Min
Search Dots
Peak to dots
Stab

- spectrum mode -> PEAK menu in channel power, adjacent channel power and occupied bandwidth

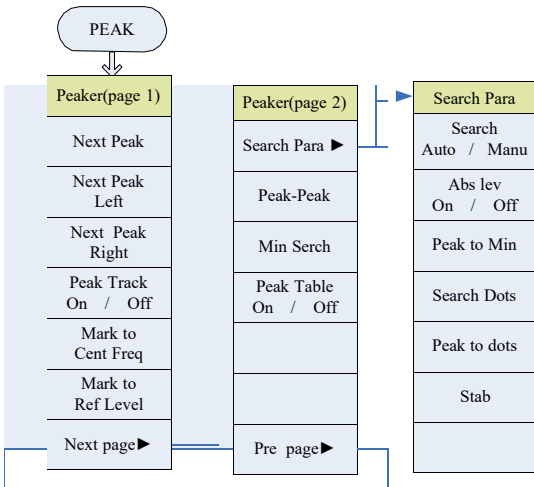

2.4.8 SAVE key

The SAVE key is a general key that has the same menu in all circumstances.

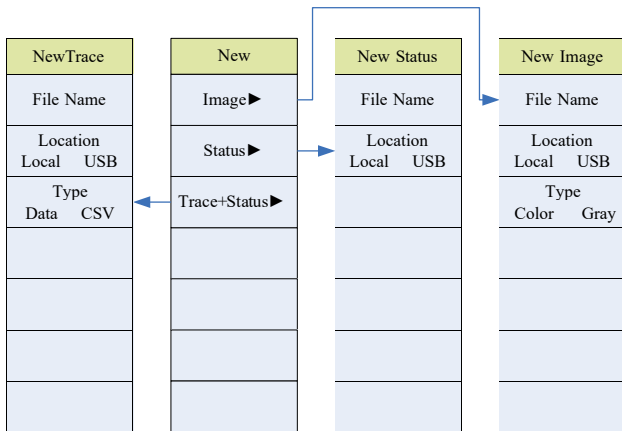

2.4.9 SYS key

The SYS key is a general key that has the same menu in all circumstances.

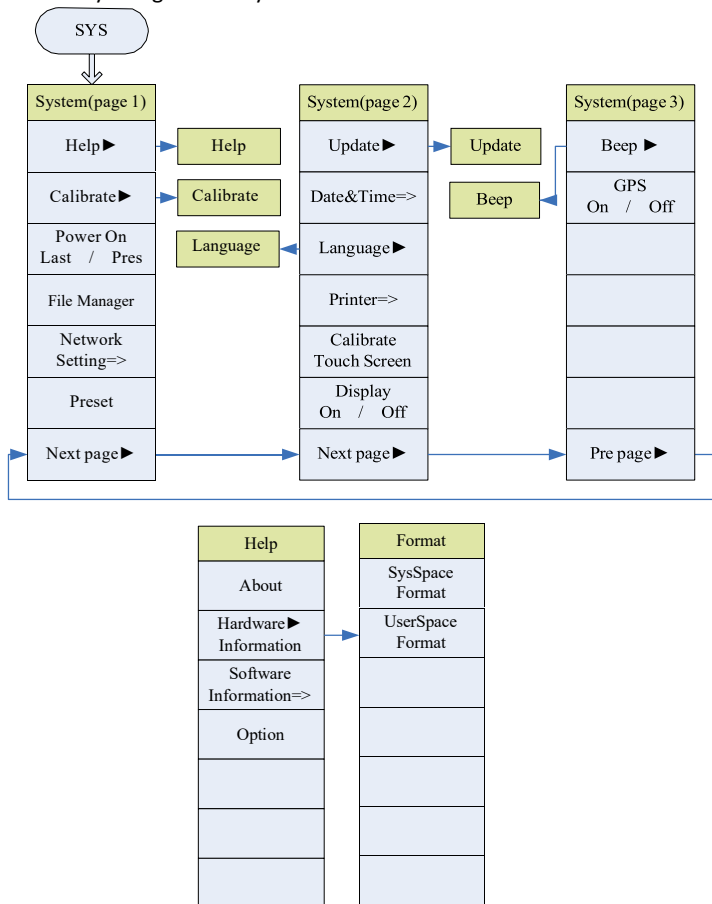

AD8000 Series Spectrum Analyzer Instruction

Beep Config	Calibrate	Language	Update
Beep Prompt On / Off	Cal Amp	English	Enter
Test Beep Prompt	Amp Corr On / Off	中文	
Beep Alarm On / Off	Resp Corr On / Off		
Test Beep Alarm			
			Cancel

3 Spectrum Measurement

This chapter includes following contents:

- Detail function and using of swept SA
- Detail function and using of channel power
- Detail function and using of adjacent channel power
- Detail function and using of occupied bandwidth

AD8000 Series Spectrum Analyzer Instruction

Before using the spectrum analyzer to measure and analyze the signal, please mind the following terms so that users could use the device safely and efficiently.

Caution:

1. If the input signal is too strong, the input attenuator and input mixer of the device might be damaged. Users should be careful when using it to measure high power radio source and transmission system. The upper limit of the input power is +30dBm.
2. If the direct voltage which is transmitted through the signal input cable is too high, the input attenuator of the device might be damaged. The maximum direct voltage should not over the maximum value 50V DC marked on the front panel.
3. To ensure the accuracy of measurement, please preheat the device for more than 10min.

3.1 Selecting Measurement Type

Pressing **MEAS** key, the submenu will appear. Well can switch the measurement type during swept SA, channel power, occupied bandwidth and ACP. The default one is the swept SA.

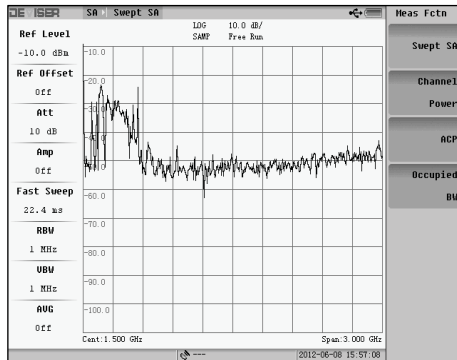

Fig. 3-1 Measurement Type Selection Menu

3.2 Function & Using of Swept SA

3.2.1 Basic measurement

The swept SA mainly measures the amplitude frequency characters of the signal. The frequency and amplitude button at the bottom of the panel are mainly used.

1 Frequency

Pressing **FREQ** key, the submenu will appear (Fig. 3-2), press 'Next page', and the second page of menu appear (Fig. 3-3). User can set center frequency, start frequency, stop frequency and etc.

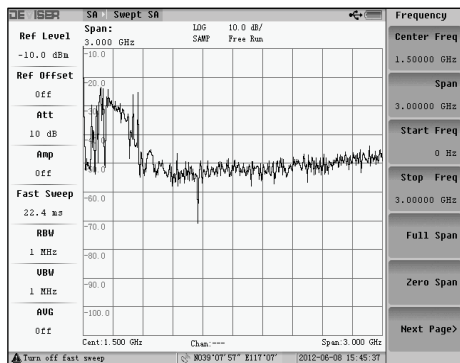

Fig. 3-2 Frequency Menu (Page 1)

AD8000 Series Spectrum Analyzer Instruction

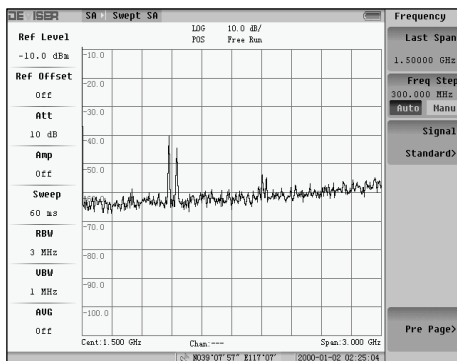

Fig. 3-3 Frequency Menu (Page 2)

(1) Center Frequency

Pressing 'Center Freq' soft-key, and the current center frequency can be changed. There are three methods to input the frequency value:

a) Directly input the number: Press the number keys, and the 'Unit' menu will appear as below. Select the unit in this menu to complete inputting.

For example: If user want to set the center frequency as 20MHz, press the number key '2' and '0' and choose the 'MHz'.

AD8000 Series Spectrum Analyzer Instruction

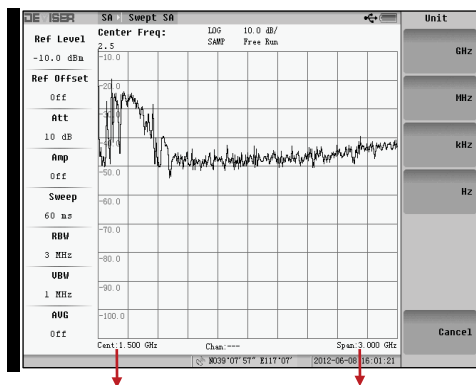

Center Frequency

sweep span

Fig. 3-4 Center Frequency Inputting

b) Press the 'Up/Down' key: each press would change the value of 'frequency step'. When the frequency step is automatic, it would move for one scale. For the frequency step, please refer to the following chapter.

c) Rotate the knob: move $1/420$ of the span each time.

Note:

1. In most parameter input cases, the hint characters will display at the upper left of the screen. The upper line is the item being entered, and the lower line is the value you enter.
2. Frequency (center frequency) could not be negative. If it is below 0, it would be processed as 0. If it is over 3GHz, it would be processed as 3GHz.

(2) Start Frequency

The start frequency is the frequency value at the very left of the screen. After pressing 'Start Freq' soft-key, users can change the current start frequency. There are three methods to input the frequency value: manually inputting the number, pressing the 'Up/Down' step key to change frequency and rotating the knob.

After setting start/stop frequency, the former center frequency and sweep span on the bottom of the screen will be replaced by start and stop frequency.

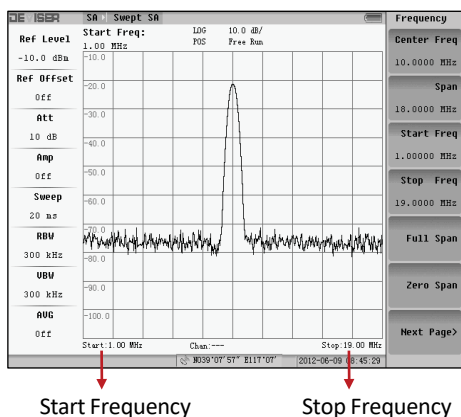

Fig. 3-5 Start Frequency

(3) Stop Frequency

After pressing 'Start Freq' soft-key, users can change the current stop frequency. There are three methods to input the frequency value: manually inputting the number, pressing the 'Up/Down' step key to change frequency and rotating the knob, the same as center frequency.

(4) Span Frequency

The span frequency refers to the differential frequency of the very right point and the very left point of the screen. It is called span for short.

Press 'Span' key to see the following menu.

AD8000 Series Spectrum Analyzer Instruction

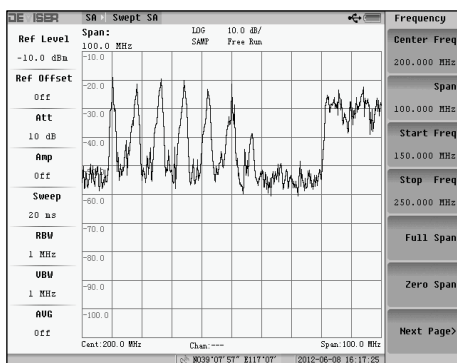

Fig. 3-6 Span Frequency Menu

The maximum span frequency of this device is 3000MHz, and the minimum is 0Hz. The larger the span frequency is, the more signals you could see with less accuracy. Inversely, the less the span frequency is, the less signals you could see with higher accuracy. Therefore, an appropriate span frequency should be chose according to the current situation in real measurement.

There are three methods to input the frequency value: manually inputting the number; pressing the 'Up/Down' step key to change frequency that the frequency would change by 1, 2, 5 steps, and the span sequence would be as following: 200Hz, 500Hz, 1KHz, 2KHz....3000MHz; and rotating the knob to change the span 1/100 each time.

Note:

1. When the RBW is fixed, the span could not be too wide, otherwise the system would remind you 'UNCAL' showing that the measurement accuracy could not be ensured.
2. It could not be zero if changing the span through up/down key.
3. If the span value is not the number in the sequence when changing through up/down key, the value would change to the lower one in the sequence. For instance, press the up step key when it is 199Hz, the value would change to 200Hz.

AD8000 Series Spectrum Analyzer Instruction

Fig. 3-7 & fig. 3-8 show the comparison of narrow span and wide span.

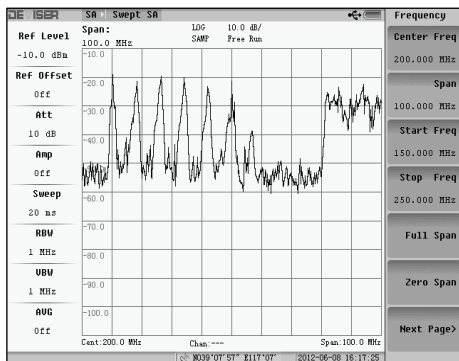

Fig. 3-7 Narrow Span

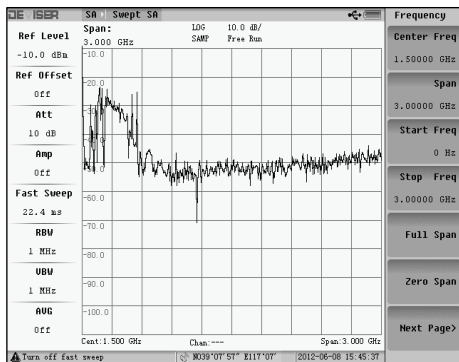

Fig. 3-8 Wide Span

(5) Full Span

Pressing this soft-key will change the span to 3000MHz.

(6) Zero Span

Pressing this soft-key will change the span to 0Hz. Zero span is the same as seeing the time domain information of selected frequency point (the sweep

AD8000 Series Spectrum Analyzer Instruction

time determines the time shaft of the time domain coordinate). The zero

AD8000 Series Spectrum Analyzer Instruction

span is very useful in measuring the low modulation frequency signal of AM & FM.

(7) Last Span

Change the current span back to last span. When the new span is inputted wrongly, this key could be used to change to the last span easily. The difference between two span could also be viewed manually.

(8) Frequency Step

The default value of 'Freq Step' is 1/10 of the span. It would move for one scale each time. After pressing the 'Freq Step' soft-key and setting it into 'Manu', the frequency step value could be changed. There are three methods to change the frequency step: manually inputting, pressing the Up/Down key and rotating the knob.

2 Amplitude

Press **AMPTD** to see the following menu:

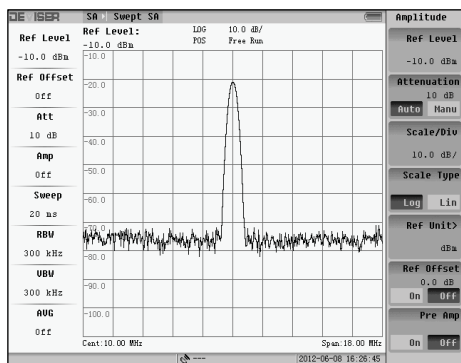

Fig. 3-9 Amplitude Menu

(1) Reference Level

Reference level is the level value displayed on the top of the screen. The default value is 98.8dB μ V (-10dBm).

AD8000 Series Spectrum Analyzer Instruction

Attention: The maximum reference level could be set as 30dBm (amplifier off), and the attenuator is 50dB at that time. As the attenuator decreasing, the maximum reference level decreases as well. See the next section for details.

The units of reference level of this device are dBm, dBmV, dB μ V, mV, V, μ V and nV. In the 75 Ω system, the conversion of each unit is as below:

Formula	Original Unit	New Unit
$\text{dBm} = \text{dB}\mu\text{V} - 108.8$	68.8 dB μ V	-40 dBm
$\text{dBm} = \text{dBmV} - 48.8$	8.8 dBmV	-40 dBm
$\text{dBm} = 20 * \log(\text{mV}) - 48.8$	2.778 mV	-40 dBm

Table 3-1 Level Unit Conversion Table

The table only shows the conversion between dBm and other units. Other units could be calculated according to this table.

3 methods of changing the reference level:

a) Input by number key: After inputting the number, the unit menu will appear. Choose the unit users need.

b) Up/down step key: the reference level would change in the amplitude of 1 scale of the vertical axis with each press. For instance if it is 10 dB/scale currently, the reference level would change 10dB with each press.

c) Knob: the change is 1/10 of the change through the up/down step key, i.e. 1/10 scale.

AD8000 Series Spectrum Analyzer Instruction

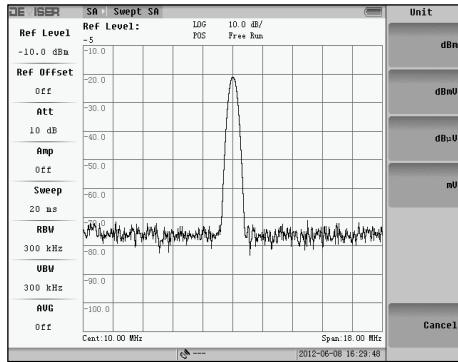

Fig. 3-10 Reference Level Inputting

(2) Attenuator

The input attenuator is an important part of the device. With the attenuator, the amplitude of input signal entering the mixer could be reduced, and then reduce the signal distortion. The range of attenuator of the device is 0dB ~ 50dB with 1dB step. The default value is 10dB.

The using of attenuator should be reasonable. The increasing of the attenuator could reduce the distortion of the mixer of the device, but increase the noise and decrease the measurement signal range. The attenuation value should be set reasonably to make the device work most efficiently.

The system would offer a suitable attenuation value automatically in auto mode. To change the attenuator, it should be set as manual with the soft-key first. Press the up/down step key or rotate the knob to change it by 5dB each time. If inputting with number keys, it could be changed by 1dB step.

If the measured signal is higher than the noise floor of the device, the noise floor would increase for the same value of the increasing of the attenuator.

Attention: the signal entering the mixer means the amplitude of the signal after passing through the attenuator. The amplitude should be less than -10 dBm. For instance, the amplitude of input signal is 0 dBm, the attenuator should be at least 10 dB, otherwise distortion or damage would happen to the device.

When the attenuator is set as manual, a '#' mark would appear at the attenuator parameter display area showing that it is manual currently. Similarly, when the RBW, VBW and sweep time are changed to manual, a '#' mark would also appear.

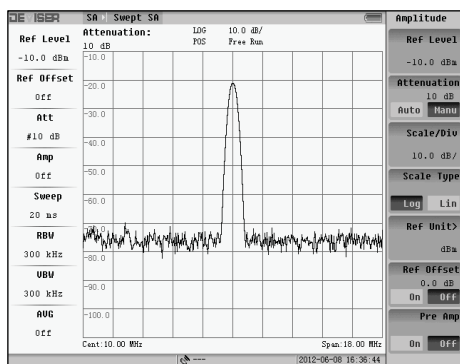

Fig. 3-11 Attenuator in Manual Mode

(3) Scale Log/Linear

In 'Log' state, the difference of Y-coordinate is in direct proportion to Δ dB, while in linear state it is in direct proportion to voltage difference Δ V. In most cases, the instrument is in logarithm state, but in some special cases (for example when measuring the modulation degree of AM), the line state is the better choice.

The common used units in logarithmic state are dBm, dB μ V and dBmV. The conversion could be checked in table 3-1. In log state unit mV could also be used. The wave will not change with the change of unit.

The common used units in line state are mV, V, μ V and nV. The wave will not change with the change of unit as well.

AD8000 Series Spectrum Analyzer Instruction

The following 2 figures show the difference measure results of the same signal, one in 'Log' state and the other in 'Linear' state.

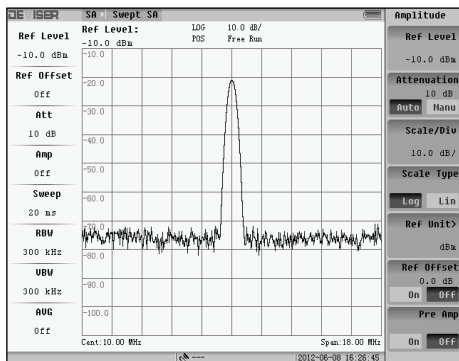

Fig. 3-12 Logarithmic state and Reference Level is -10 dBm

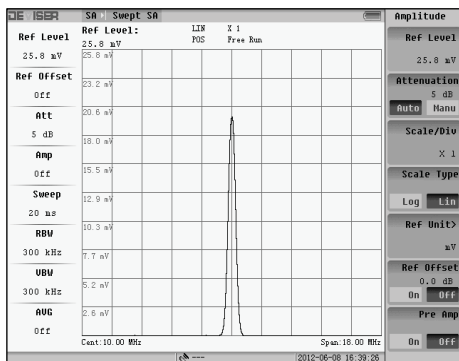

Fig. 3-13 Linear state and Reference Level is 70.8 mV

(4) Unit

Press the corresponding unit soft-key, and the amplitude unit sub-menu would pop-up. For example, the current unit is dB μ V. Press the soft-key **dBm** to change it to dBm

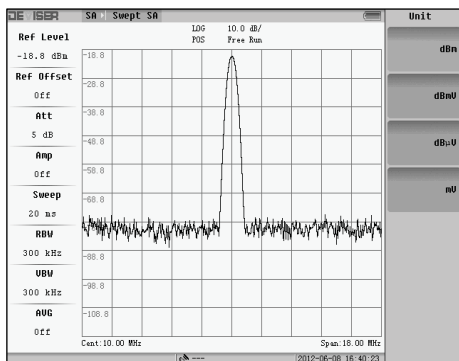

Fig. 3-14 Amplitude Unit

Note: The change of unit will not cause the change of 'Log/Line' state.

(5) Scale/Div

It shows at the top of the screen. It is also divided into 2 kinds log and linear.

In log state, it refers to how many dB changing with each scale. The default is 10dB/div. After pressing 'Scale/Div' soft-key user can enter the integer number from 1 to 40 or decimal number from 0.1 to 0.9 to change the scale to the state wanted. The scale/div can be changed by 'Up/Down' cursor or by knob too.

In linear state, scale/div shows in multiple ($\times n$). The default multiple is 1. After pressing 'Scale/Div' soft-key, the submenu of it will appear. Users can choose $\times 1$, $\times 2$, $\times 5$ or $\times 10$ in this submenu. Random number is not available. $1/n$ is the ratio of voltage difference between the lowest level displayed on the screen and reference level. For example when reference level is 1mV, if the Scale/Div is $\times 1$, the lowest voltage display on the screen is 0mV, while if

AD8000 Series Spectrum Analyzer Instruction

the Scale/Div is $\times 2$, the lowest voltage display on the screen will be 0.5mV, and etc.

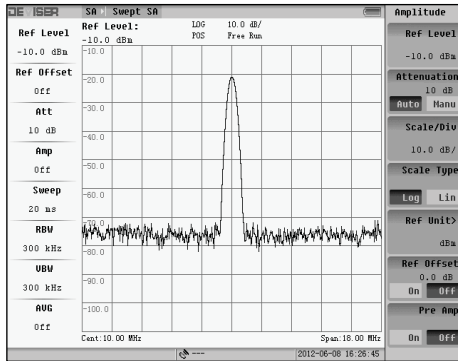

Fig. 3-15 Log: 10dB/div (Default)

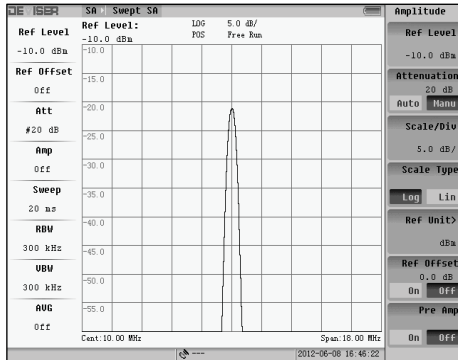

Fig. 3-16 Log 5dB/div

AD8000 Series Spectrum Analyzer Instruction

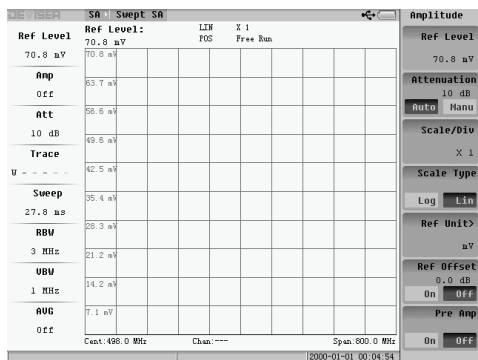

Fig. 3-17 Linear: $\times 1$ (Default)

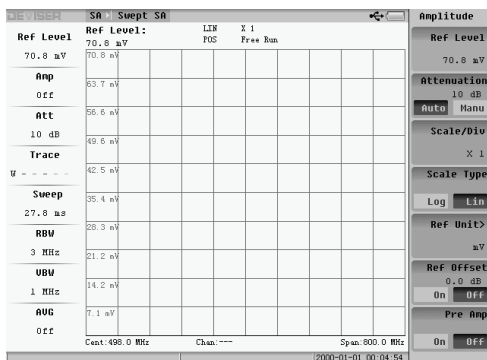

Fig. 3-18 Linear: $\times 2$

No matter in 'Log' or 'Line' state, the change of 'Scale/Div' will only change the displace scale, but not the measurement value.

AD8000 Series Spectrum Analyzer Instruction

(6) Reference Offset

When ref offset is turned on, if it is set as 10dB, the reference level and signal amplitude would move upwards 10dB.

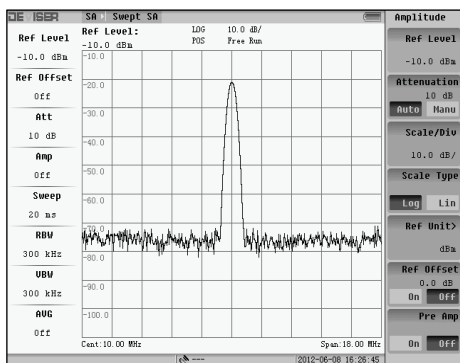

Fig. 3-19 Ref Offset Off

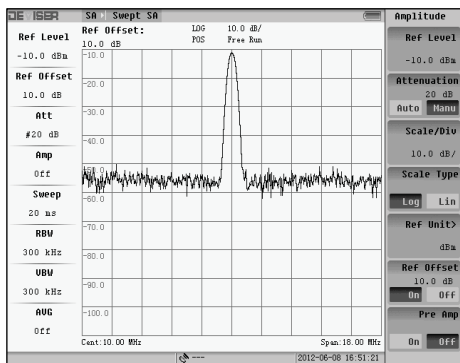

Fig. 3-20 Ref Offset 10dB

AD8000 Series Spectrum Analyzer Instruction

When the display scale is linear or the reference level unit is linear unit, the unit of ref offset is also dB. The conversion is as below:

$$\text{Linear Unit} = 10^{\frac{dB}{20}} ;$$

If the ref offset is set as 6 dB, the linear unit value would double.

Changing ref level could be done with number keys, un/down key and knob.

(7) Pre Amplifier

There is a pre amplifier which could be switched on or off in AD8000. When the signal amplitude is too low to measure, the pre amplifier could be switched on to increase the system measurement range.

When the pre amplifier is on, the attenuator would increase 20dB automatically to avoid saturation. If the attenuator is in manual mode, the reference level would decrease 20dB.

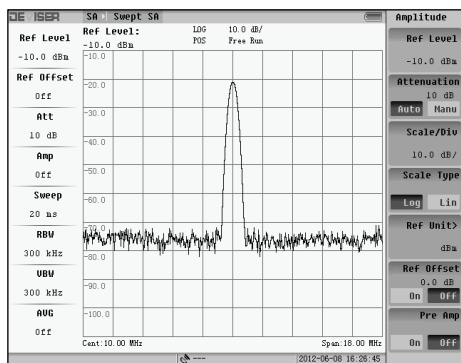

Fig. 3-21 Pre Amplifier off

AD8000 Series Spectrum Analyzer Instruction

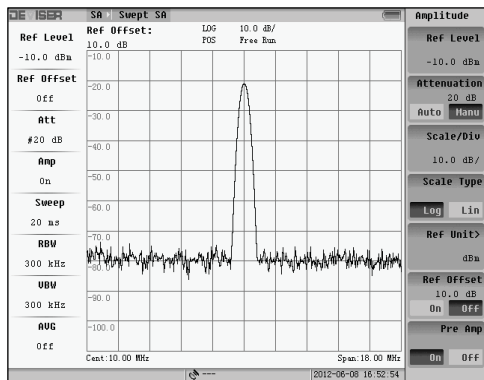

Fig. 3-22 Pre Amplifier on

3.2.2 Basic Parameters Settings

The basic parameters refer to the RBW, VBW, video average, sweep mode, sweep time, trig mode and etc. of the device. This part is mainly used to set the parameters of the medium frequency receipt unit of the spectrum analyzer.

The basic parameter is set with the **CPL** key. It is at the upper right corner of the operation panel.

Press the soft-key, and the following menu would pop up.

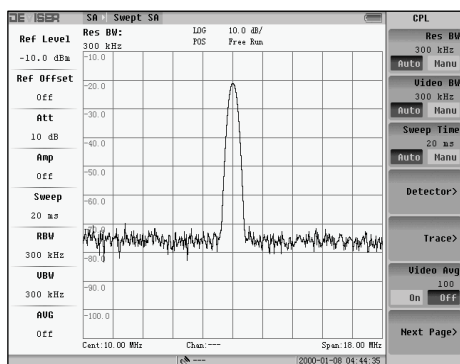

Fig. 3-23 Basic Parameters Settings Menu

1 BW Settings

(1) RBW

Resolution bandwidth (RBW) refers to the IF filter bandwidth of the spectrum analyzer. RBW defines the smallest frequency difference of two adjacent signals that can be distinguished by the spectrum analyzer. So the narrower the RBW is set, the higher precision the spectrum has. But it needs more establish time with narrow RBW. If the sweep time cannot fulfill the requirement of RBW, the system will give the prompt 'UNCAL'.

AD8000 Series Spectrum Analyzer Instruction

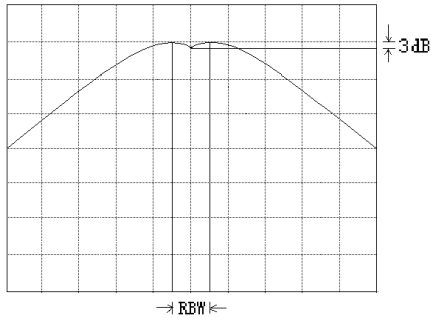

Fig. 3-24 Max. Medium Frequency BW between 2 Signals

Moreover, when RBW is fixed, the span frequency has a range. When the ratio of span frequency and RBW is less than a certain value, it would remind as 'UNCAL'.

Changing method: R The RBW can be changed from 1kHz to 3MHz, taking the step 1 and 3. After setting the 'Res BW' to 'Manu' state, users can change the RBW by inputting the number, pressing the 'Up/Down' cursor or rotating the knob. The symbol of '#' would appear in parameter table at the left.

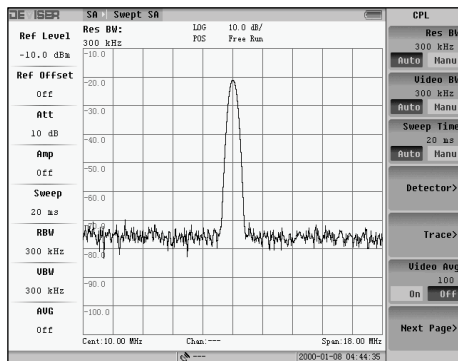

Fig. 3-25 RBW Menu

AD8000 Series Spectrum Analyzer Instruction

(2) VBW

Video bandwidth (VBW) is very useful to detect the signal in the noise. It is the lower pass filter after the IF filter which is used to average (smooth) the noise. This process could make the s/n increases about 10dB. To improve the filter's effect, users should manually set the VBW as 1/10 or smaller of the RBW. When VBW is set to 'Auto', the VBW will change and equals to RBW. The decreasing of VBW would increase the sweep time. Two figures below show the influence of different VBW towards the wave.

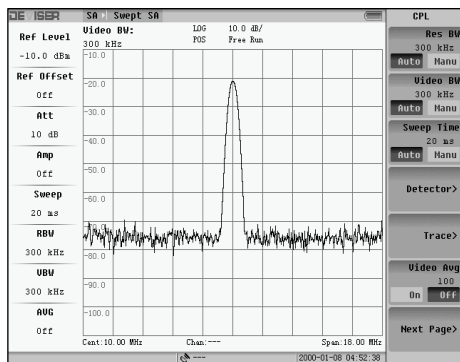

Fig. 3-26 Large VBW

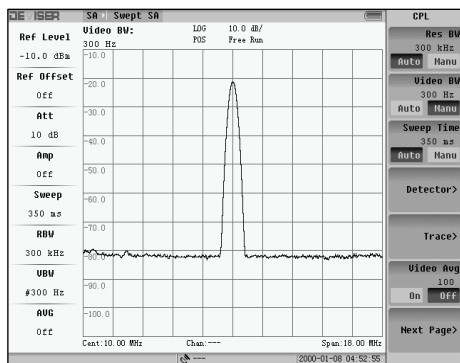

Fig. 3-27 Small VBW

AD8000 Series Spectrum Analyzer Instruction

In the figure above there is a '#' before VBW, in which '#' indicates that VBW parameter is in 'Manu' state now.

(3) Video Average

Set the 'Video Avg' to 'On', then the spectrum will calculate the average value of current trace and previous traces values. The more times the video average, the more previous data it would take. The default state of 'Video Avg' is 'Off'.

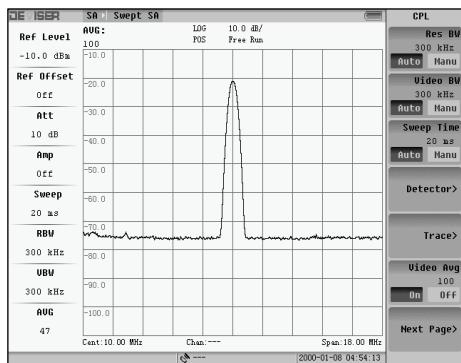

Fig. 3-28 Video Average On

The video average, same as decreasing VBW is very important to add S/N, but it is faster than the later. In fact video average only collects data once, and the average is calculated by the computer. VBW is increasing the charging/discharging time of the capacity in hardware. In video average mode, the detection mode is set as sample mode automatically.

Turn on the corresponding soft-key to turn on the video average mode. The default average time is 100. Press the number keys to enter the time (1-100). The average time would be shown at the left of the screen when video average is on.

2 Sweep Mode, Sweep Time

(1) Sweep Time

The sweep time mainly depends on span, RBW and VBW. It is in direct proportion to span, and in inverse proportion to RBW and the minimum value of RBW and VBW (the sweep time could be set randomly when the span is 0). If the sweep time is too short, the system would remind 'UNCAL'. Users need to increase the sweep time manually with the number keys, knob or up/down key.

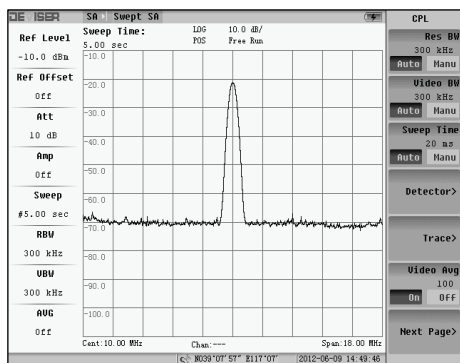



Fig. 3-29 Long Sweep Time

AD8000 Series Spectrum Analyzer Instruction

(2) Sweep Mode

There are two sweep modes; one is continuous (Cont) and the other is single (Sig). The default mode is continuous mode. If users wants to set the sweep mode to single mode, users can set the 'Sweep' soft-key into 'Sigl' or press the 'Single Sweep' sub-key to activate a single sweep; at the same time a  mark would show up at the upper right corner of the screen.

Single Sweep Mark

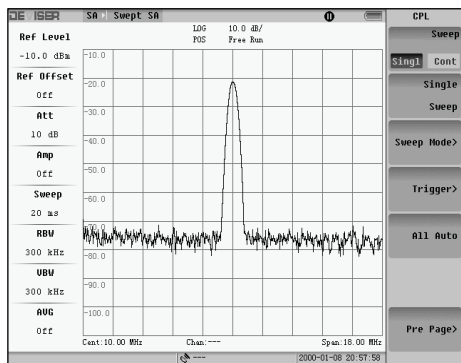

Fig. 3-30 Single Sweep

That image would sweep from left to right one time and then stop. Press the key again to start another single sweep. Switch the soft-key to continuous mode to change.

(3) Full-Automatic

Press the full-automatic soft-key to change all attributes including RBW, VBW, attenuator, sweep time, frequency step and etc. into automation.

3 Multi-trace Function

Press the trace key, and the follow menu will pop up

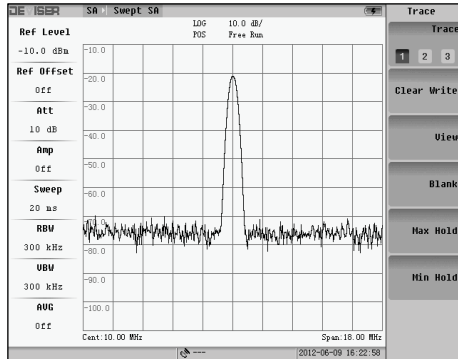

Fig. 3-31 Trace Menu

(1) Trace selection

There are three traces that users can choose 1, 2, 3, 4, 5 and 6. Users can switch during these trace by press 'Trace' soft-key. What are called three traces are the different waves of the same input that only were viewed in different time and different parameter settings. Three traces are showed by different colors.

(2) Write

Write is also called refresh, i.e. normal status

(3) Hold

Press the 'Hold' soft-key, the current active trace will be hold no matter you change reference level or span. Parameters could be changes when changing to another trace. The following figurer is that trace 2 is hold. It could be seen that the wave below keeps refreshing, but the one above is still.

(4) Erase

Erase means to stop displaying one trace no matter what status it is.

AD8000 Series Spectrum Analyzer Instruction

(5) Max. Hold

'Max. Hold' mode is similar to 'Write' Mode, but the wave shown on the screen will keep the largest value comparing with the history after 'Max Hold' mode is selected.

(6) Min. Hold

'Min. Hold' is similar to 'Max. Hold'. It saves the level value of the lowest points.

4 Detection Mode

AD8000 series spectrum analyzer has up to 7 detection modes.

(1) Sample

Sample detection is a detection mode which does not process the signal specially. It could be used to observe the noise signal well.

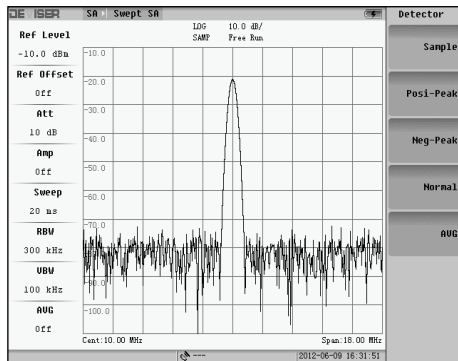

Fig. 3-32 Sample Detection

(2) Positive-Peak

When the sweep time is long enough, the positive peak detection mode could get the largest envelop of the signal. Sometimes, when the modulation signal is measured, this mode could eliminate the modulation interference, and get the stable amplitude of the signal. The enough sweep time does not means that 'UNCAL' does not show up. The time should be longer, since the calculation of 'UNCAL' is gotten according to sample detection mode. It usually needs 1~3 times of the minimum time.

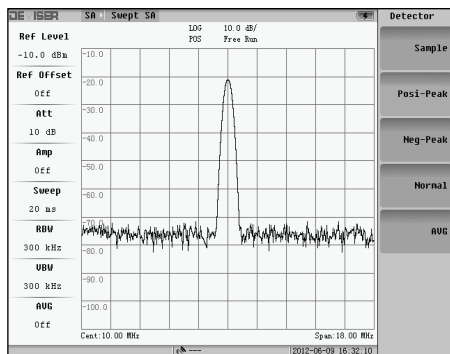

Fig. 3-33 Positive Peak Detection

With the sample detection mode and a relative wide span, the RBW could not always cover all signals. Presume the current span is 16MHz, and RBW is 1MHz. if there are 16 points on the screen, it would shows as below:

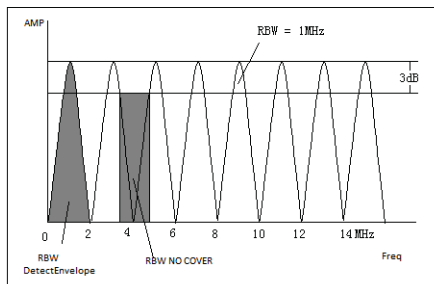

Fig. 3-34 RBW Detection Wave Envelop

AD8000 Series Spectrum Analyzer Instruction

For the signal with 3MHz as the frequency, it just falls in the 3dB bandwidth of the second RBW detection envelop. The value currently shown is accurate. If a 3.5Mhz signal inputs, and also falls in a valid RBW detection envelop, the value is also accurate. But if a signal with the frequency between 3.5 and 4.5MHz , it would fall out of the 3dB envelop. The RBW at that time could not cover it. The measured signal amplitude in sample detection mode would be lower than the actual value, since it is at the sideband of the RBW but not the valid 3dB bandwidth.

In this circumstance, it could be avoided with the positive peak detection mode if the span/RBW is not too large.

(3) Negative-Peak

The function of negative peak is the opposite of the positive peak that it could measures the minimum envelop of the signal. But it is not that common in use than the positive peak detection.

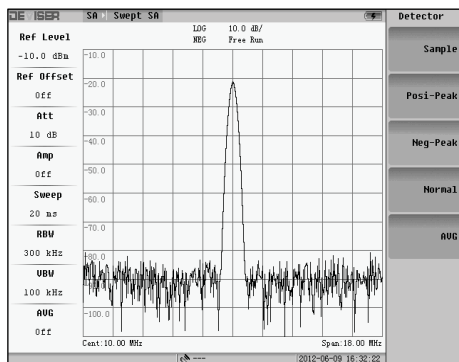

Fig. 3-35 Negative Peak Detection Mode

(4) Normal

From the wave it could be seen that the signal amplitude remains the same, but the amplitude of the noise increases. It is because that to estimate the collected data in this detection mode: the signal uses positive peak detection, but the noise part adapts random processing method, for example odd point with positive peak, and negative peak for even point.

AD8000 Series Spectrum Analyzer Instruction

This mode also needs enough sweep time.

AD8000 Series Spectrum Analyzer Instruction

Since the signal adapts positive peak detection mode, leaking point in sample mode could be avoided. The noise is not detected with positive peak, so it would not rises.

(5) Average

This mode averages when sampling.

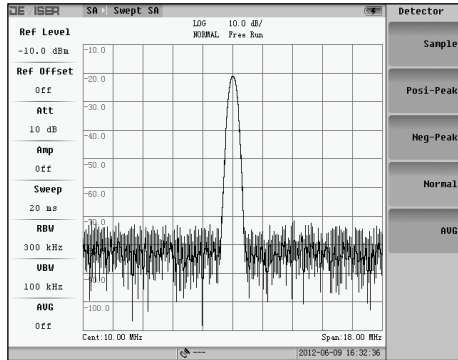

Fig. 3-36 Normal Detection

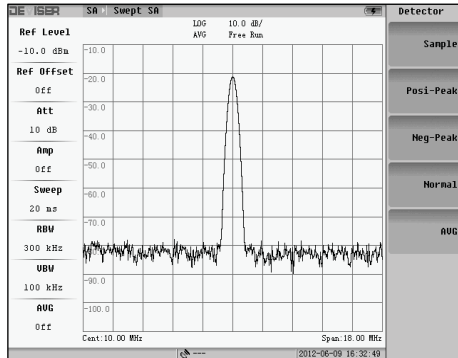

Fig. 3-37 Average Detection

(6) Root-Mean-Square

This mode is to measure the valid value when measuring.

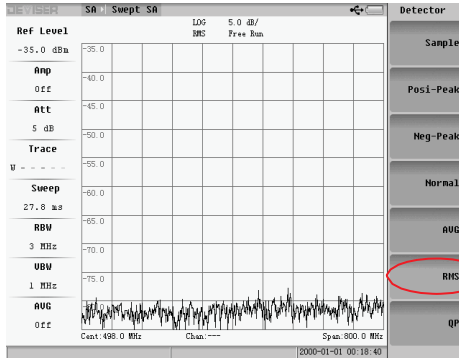

Fig. 3-38 Root-Mean-Square Detection

(7) Quasi-Peak

The charged and discharged time constant of this mode is in between of peak and average value. The detector output in the measurement period is relevant to both pulse amplitude and pulse repetition frequency. The effects towards output and interference of it are the same.

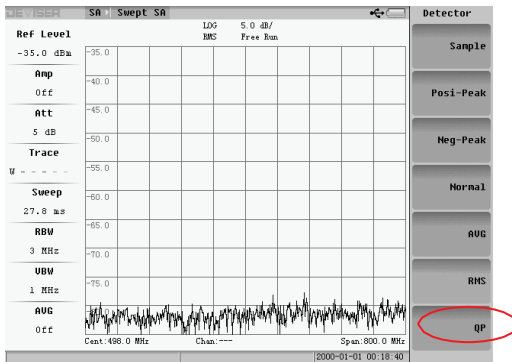

Fig. 3-39 Quasi-Peak Detection

5 Trigger Mode

Press the Trigger soft-key, and then the submenu will pop up.

The default mode is free trigger, and the device does not do any process in free trigger mode.

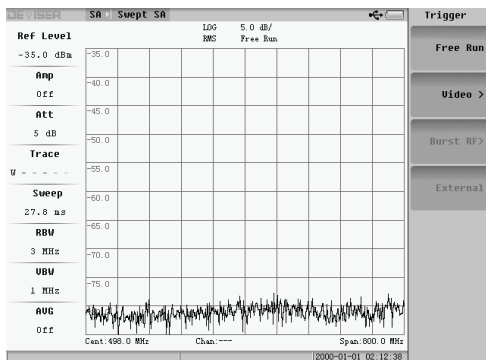

Fig. 3-40 Trigger Mode

3.2.3 Measurement Parameter Settings

The **MEAS** key is used to set some special functions of the measurement parameters. Press the key, and the following menu would pop up

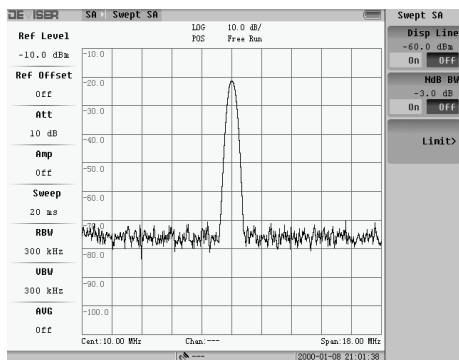

Fig. 3-41 Measurement Parameter Settings Menu

1 Display Line

Set 'Disp Line' to 'On', a red line will appear in the middle of the screen. When move the line with the up/down key or the knob, the amplitude information would change as well.

The comparison function could be turned on with display line on. After turning on the function, the system would record the amplitude information of the signal which is a wave. After that, the differential value of new data and saved data would show up near the display line. From the following figure, it could be seen that since the signal is relative stable, the fluctuation of the comparison of the signal and display line intersectant part is relatively small. Since the noise is produced randomly, the fluctuation is relatively large.

It is generally suitable that the display line is at the center of the screen when turning on. But when the signal is too small, it could be adjusted manually.

AD8000 Series Spectrum Analyzer Instruction

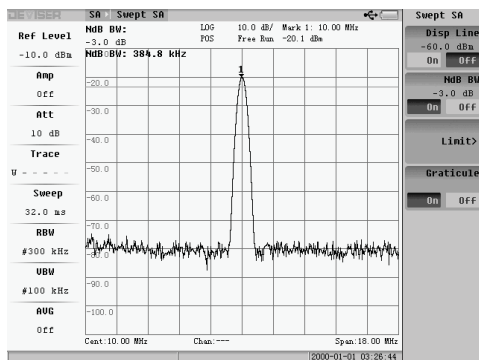

Fig. 3-42 Original Display Line

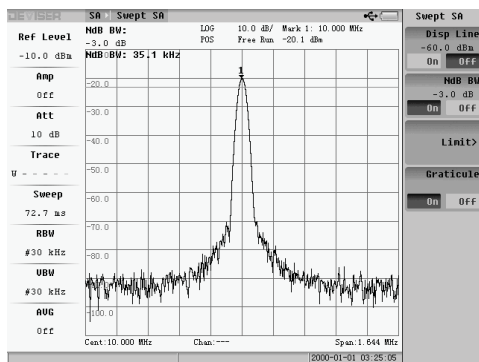

Fig. 3-43 Display Line after Adjustment

1 NdB BW Measurement

The NdB BW soft-key could be seen. The NdB BW is mainly used for measuring the RBW of the analyzer. It could only be used in log mode. The default is to measure -3dB BW when turning on, i.e. the frequency different of the two points which are 3dB lower than the maximum amplitude. The NdB value could also be entered manually.

If the corresponding BW value could not be found, the system would remind no NdB BW found at the center of the screen.

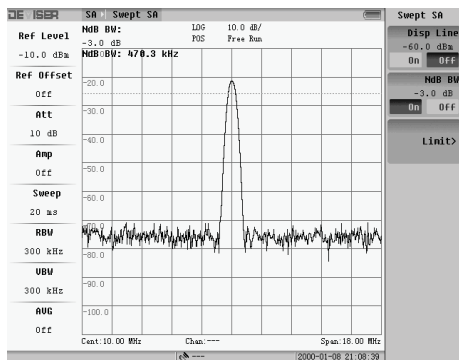

Fig. 3-44 NdB Menu

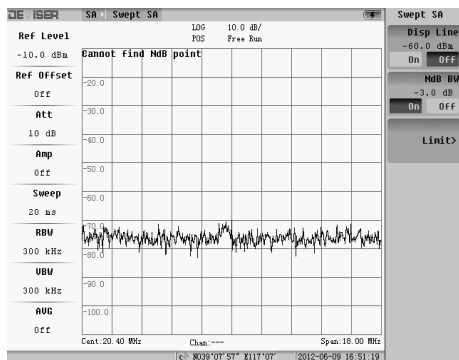

Fig. 3-45 No NdB BW Found

2 Limit

The limit is used to set the ceiling and floor of the spectrum. If the spectrum is over the ceiling or floor, 'Not Qualified' would show.

3.2.4 Basic Usages

Basic usages mainly include marker and peak value functions.

The mark function is to mark at a certain trace point to observe its amplitude and frequency (Y-axis & X-axis) information; the peak value function is used to find out the maximum amplitude point of current trace automatically. See the following part for details:

1 Mark

Press the **MARK** key, and the first page of menu will appear; press the 'Next page' sub-key, and the second page of menu will appear.

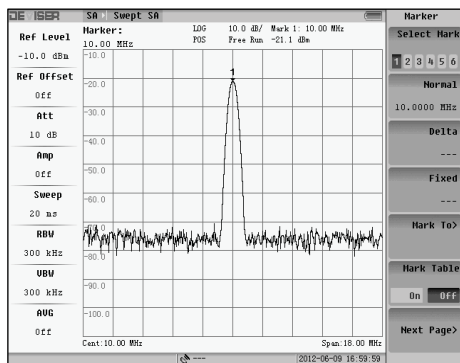

Fig. 3-46 Mark Menu (Page 1)

AD8000 Series Spectrum Analyzer Instruction

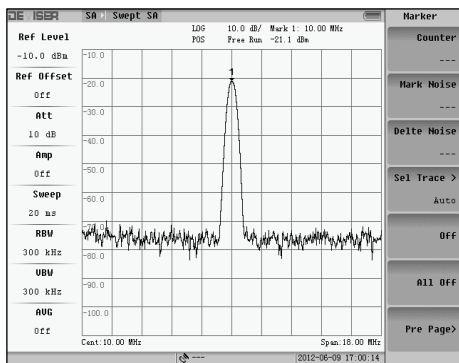

Fig. 3-47 Mark Menu (Page 2)

If there is no marker on, the system will automatically turn on the normal marker. If there are some markers on, the state of these markers will remain unchanged.

(1) Normal Marker

After pressing the 'Mkr Normal' soft-key or pressing NORMAL key while no marker is on, the normal marker will appear on x-axis at the center of the screen moving up and down with the change of the amplitude. At the same time the amplitude and frequency/time information of this marker will be displayed on the up-right of the screen.

The signal amplitude would be read directly after turning on the marker. Generally AD8000 series spectrum analyzer displays 2 digits after the decimal point to show the amplitude in log unit. In linear unit 5 significant digits would be saved.

When the span is zero, the wave display on the screen is a time domain wave, so the x-axis changes from frequency to time. The start time is zero and the stop time is equal to sweep time. The displayed marker information changes to time as well.

The y-axis of the marker is signal amplitude which is not changeable. The x-axis could be changed in 3 methods:

- a) Press 'Up/Down' key. The step change of this method is 1/10 of span.

AD8000 Series Spectrum Analyzer Instruction

- b) Rotate the knob. The step change is 1/500 of the span.
- c) Manually input the frequency. When the span is zero, it could not be entered manually. Only 2 methods before are usable.

(2) Delta Mark

After pressing this soft-key, two markers will appear on the screen. The start positions of these two markers are the same, so the amplitude difference and frequency/time difference here are 0. Rotating the knob, pressing the 'Up/Down' cursor or manually inputting the frequency value can change the position of the second marker. The amplitude and frequency/time difference between two markers will be displayed on the up-right of the screen. The main function of 'Delta Mark' is to compare two signals.

(3) Fixed Mark

'Fixed Mark' is similar to 'Delta Mark': the main function is also to view the difference of two markers and the method to change the position of the second signal is the same. Differently, the first marker of delta mark indicates the signal frequency and amplitude of that point, but the first point of fixed marker indicates the amplitude of that frequency point which has nothing to do with the signal. The marker would remain at the original amplitude if the signal amplitude increases. Its position will not change with the signal again only if the reference level or the frequency is changed (the frequency and amplitude of the frequency point remain unchanged).

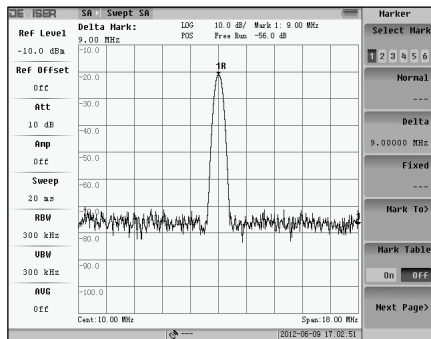

Fig. 3-48 Delta Mark

AD8000 Series Spectrum Analyzer Instruction

(4) Marker to >

In normal mark mode, press the key, and the following submenu will appear. Set the level of current marker as reference level through 'Marker to ref level' soft-key. Set the frequency of current marker as center frequency through 'marker to center frequency' soft-key.. At the same time the span BW is modified automatically.

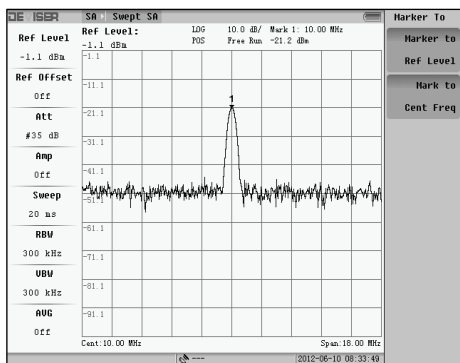

Fig. 3-49 Before Marker to Ref Level

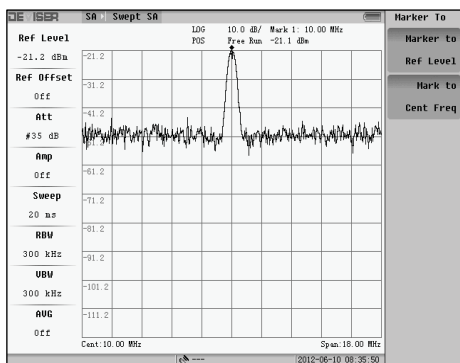

Fig. 3-50 After Marker to Ref Level

AD8000 Series Spectrum Analyzer Instruction

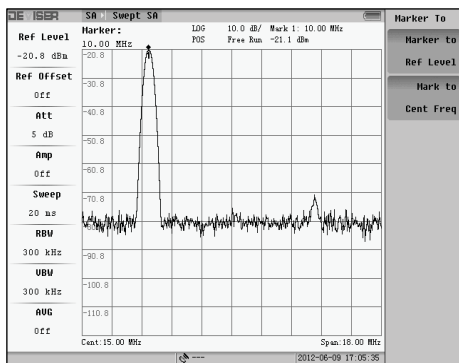

Fig. 3-51 Before Marker to Center Frequency

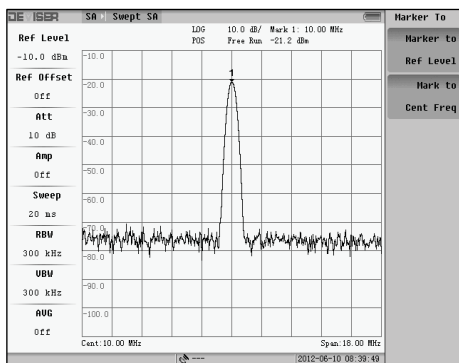

Fig. 3-52 After Marker to Center Frequency

(5) Multi-marker & Marker List

AD8000 could open up to 6 markers. The 'Select Mkr' key could be used to switch between the 6 markers. The selected marker could be set as on or off with the marker switch. The frequency marker below shows the status of the marker when switching.

The marker would be changed to active marker after turning on, and the original position is the position of the previous active marker. The so-called active marker means a marker which could shuffle. After pressing 'Select

AD8000 Series Spectrum Analyzer Instruction

Mkr' or 'Marker' soft-key, the position of active marker could be changed with the same method of normal marker.

The marker list function is to record the information of all markers into a list to view together (the active frequency point is still only one), shown as the figure below:

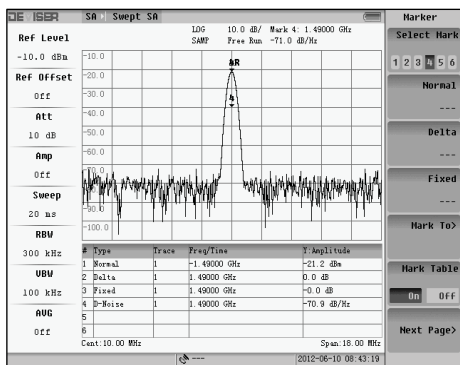

Fig. 3-53 Multi-marker & Marker List

Note: When switching between 'Mkr Normal', 'Delta Mark', 'Fixed Mark' and multi-markers, other markers will automatically be set to 'Off'.

(6) All off & off

After pressing 'Next Page', 'Off' soft-key could be pressed to turn off current marker and 'All off' key to turn off all current markers.

(7) Count

Press 'Count' key, and the following menu would pop up

The frequency count function could calculate the frequency of the point with the maximum amplitude accurately to HZ, equivalent to frequency meter function. Press the frequency countm and the following interface would pop up that the frequency would show on the menu key.

AD8000 Series Spectrum Analyzer Instruction

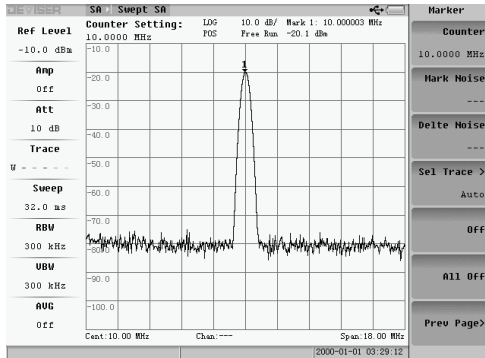

Fig. 3-54 Frequency Count

Note: If the 'Count' soft-key is set to 'On', the displayed frequency will change from the frequency of marker to the frequency of the strongest signal around the marker. The amplitude is the amplitude of that point.

(8) Mark Noise

After turning the mark noise function, users could measure the average power of the noise.

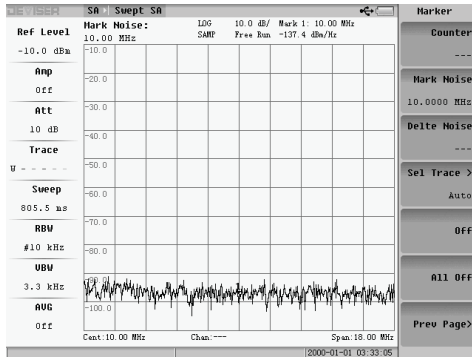

Fig. 3-55 Mark Noise ON

AD8000 Series Spectrum Analyzer Instruction

After turning on the mark noise, the system would turn the detection mode to sample automatically, and change the marker value to dBX/Hz. The noise marker is to calculate the average value of the amplitude values of 16 points from the left and right and then plus some correction factors:

Noise mark value (dB) = average amplitude of points around the marker (dB) - $10\log(\text{RBW}) + 2.5 - 0.38$

RBW means resolution bandwidth

2.5 (dB) is the correction of log conversion

0.38(dB) is the correction of gaussian filter wave

The spectrum analyzer is a voltage meter with log as the display result. The measured voltage is converted to log value, so the signal and noise power amplitude range on the same screen would be quite wide. However, the noise measurement is hard to be accurate to lower than 2.5dB with this method. It includes 1.05dB produced by Gaussian noise distribution which is also called rayleigh distribution envelop detection, and 1.45dB brought by voltage converting to log. Since it is produced by log amplifier and detector, it must be corrected.

Since it is an average value, the amplitude shown by the marker may not on the wave. As the figer above, the marker is placed at the top of the wave. After turning on the mark noise, since the amplitude of points around are all lower than the amplitude of the marker, the marker is 'suspended in the air'.

(9) Differential Noise

The differential noise would open 2 marker, one indicating current amplitude, and the other for marker noise function. The differential value would show.

AD8000 Series Spectrum Analyzer Instruction

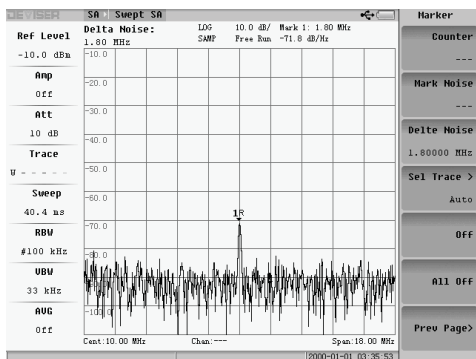

Fig. 3-56 Differential Noise ON

2 Peak Value Function

Press **PEAK** key, and the first page of peak menu will appear. The second page will appear if 'NEXT page' button is pressed.

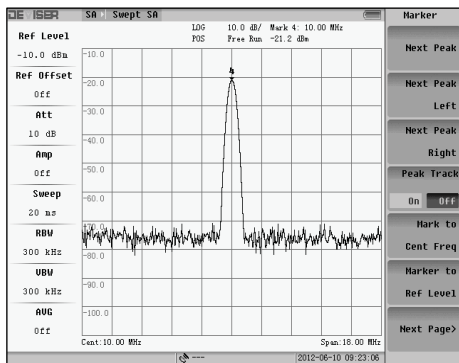

Fig. 3-57 Peak Menu (Page 1)

AD8000 Series Spectrum Analyzer Instruction

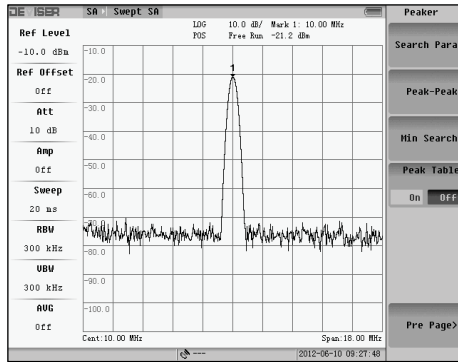

Fig. 3-58 Peak Menu (Page 2)

If the peak list is not open, the maximum amplitude value would be found with each press of the peak key and marked with a marker.

(1) Next Peak, Next Right Peak & Next Left Peak

Next Peak: Search for the hypo-peak value that is lower than the marked one. The second, third and etc. peak value would be found with continuous press.

Next Right Peak: Search for the hypo-peak value on the right side of current marker.

Next Left Peak: Search for the hypo-peak value on the left side of current marker.

(2) Peak Track

Set the 'Peak Track' to 'On', and the system will search the peak with the change of the wave automatically. Otherwise the peak marker will remain unchanged.

Marker to Center & Marker to Ref Lvl

AD8000 Series Spectrum Analyzer Instruction

When the peak list is off (there is only one marker 'On'), press 'Marker To Center'/'Marker To Ref Lvl'. The same as the function of 'Mkr to Ref Lvl' of the mark, it can set the frequency/amplitude of current marker to center frequency/reference level.

(3) Track Mode

Press 'Track mode', and the following menu would pop up.

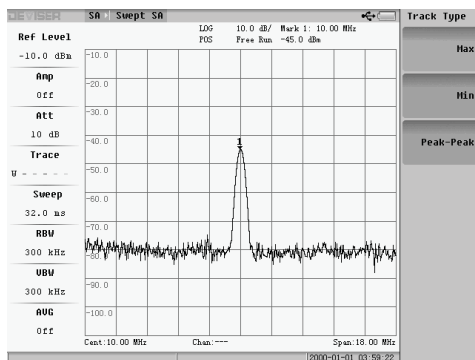

Fig. 3-59 Search Condition

(4) Peak-peak & Min Search

Press the 'peak to peak' key, and the amplitude of the highest frequency will be marked within the span on the top of the screen;

Press the 'minimum', and the amplitude of the lowest frequency within the span will be marked on the top of the screen.

(5) Peak Table

Shown as the figure, the peak table is similar to the marker table. The system would find out 6 maximum values after opening the peak table, rank the 6 peaks according to frequency or amplitude, and show the frequency/time and amplitude in the window below. The horizontal position of the marker would change as the field, and track the 6 peaks simultaneously.

AD8000 Series Spectrum Analyzer Instruction

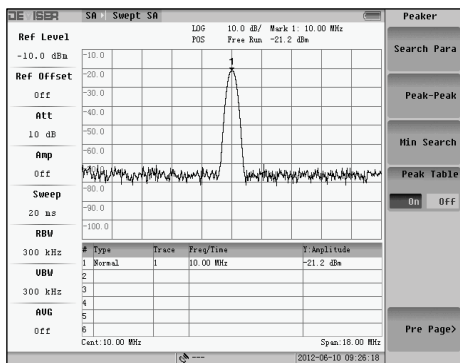

Fig. 3-60 Peak Table

3.3 Channel Power

Channel Power refers to the total power of the signal in certain span. Select a type of measurement for channel power, and the following menu will pop up.

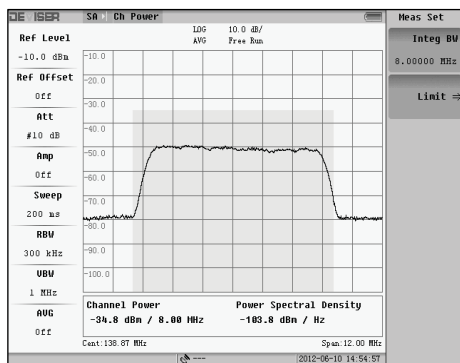

Fig. 3-61 Channel Power Interface

In the figure above, the area with a color background is the Channel Bandwidth; the height is the total power of channel. In the parameter window at the bottom, the channel power parameter represents the overall power of the channel under test, the spectral density of channel power stands the average power per Hz within the channel bandwidth.

3.3.1 Basic Measurement

1 Frequency

Press **Freq** key, and the following menu will pop up. Users can set up center frequency and frequency step of the channel power measurement. The method of setup is the same as the setup of Swept SA that we do not list again.

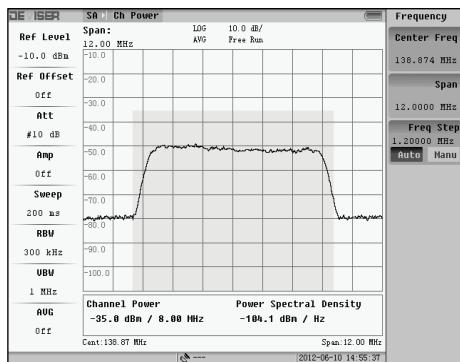

Fig. 3-62 Channel Power Frequency Menu

2 Amplitude

Press the **AMPTD** key, and the following menu will appear.

The default setup of system is Auto level on. To measure currently, if the signal has relatively large fluctuations, the system will automatically adjust the attenuator and amplifier, in order to make sure that the input power is neither overload nor too low. If the automatic level is OFF, users can modify the magnitude parameters manually, such as reference level.

AD8000 Series Spectrum Analyzer Instruction

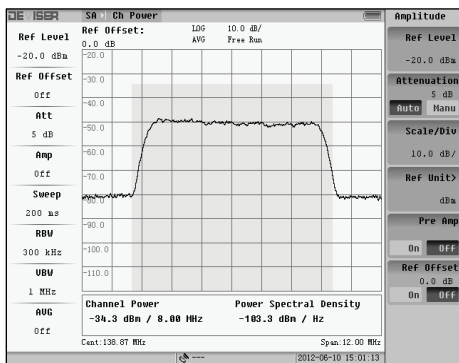

Fig. 3-63 Channel Power Amplitude Menu

(1) Reference Level

The function of Ref Level is same in a certain type of frequency scan. Changing the Ref Level only changes the display position of wave, not the measurement of span power. The method of modifying Ref Level is the same as spectrum scan. The follow 2 figures show the influence to wave when changing the Ref Level in same measurement conditions.

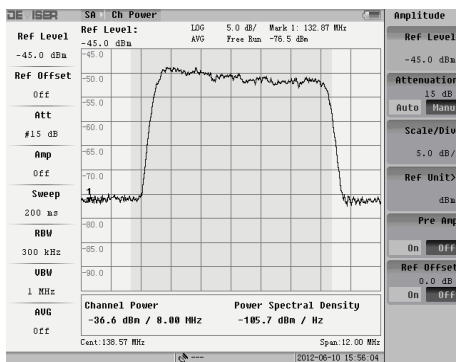

Fig. 3-64 Small Reference Level

AD8000 Series Spectrum Analyzer Instruction

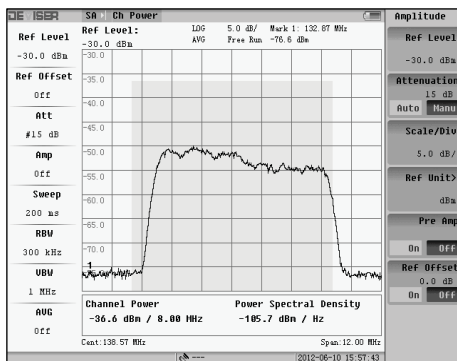

Fig. 3-65 Reference Level -30dBm

(2) Attenuator & Amplifier

The functions of attenuator are the in spectrum sweep function. It can reduce the signal distortion and the amplitude of input signal entering the mixer. The value of attenuator is from 0 to 55dB with 5dB step, and the default value is 10dB. In auto mode, the system can automatically provide a suitable value of attenuator. If users want to change the attenuation value, users should firstly set the 'Atten' soft key to 'Manu', and then input the value by number keys, 'Up/Down' key or the knob. With the 'Up/Down' cursor or the knob, the change step is 5dB. When inputting value by number keys, the step is 1dB. If the measured signal is higher than the noise base of the instrument, the attenuation will increase generally, which would bring the same value increasing of the noise base.

Figure 3-66 and 3-67 show the measurement results under different attenuator. From the channel power measurement parameters and the blue background height of channel power, we can see the influence of attenuator on the waveform. At the same time we can also observe the impact of the attenuator the noise floor.

Inside the instrument there is a switch for preamplifier, when the signal amplitude is too small to measure, you can switch on this amplifier to increase the system test range.

AD8000 Series Spectrum Analyzer Instruction

Figure 3-68 and 3-69 show the measurement results when the amplifier is close and open. From the channel power measurement parameters and the blue background height of channel power, we can see the impact of amplifier on the waveform.

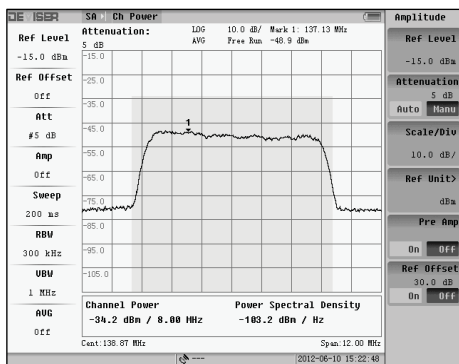

Fig. 3-66 Attenuator 5dB

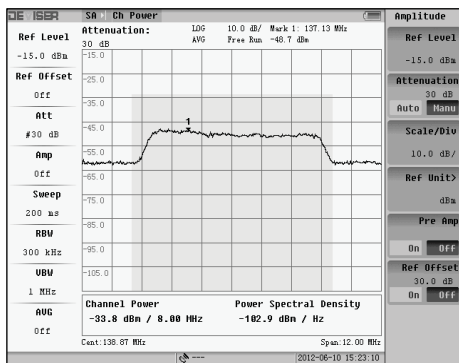

Fig. 3-67 Attenuator 30dB

AD8000 Series Spectrum Analyzer Instruction

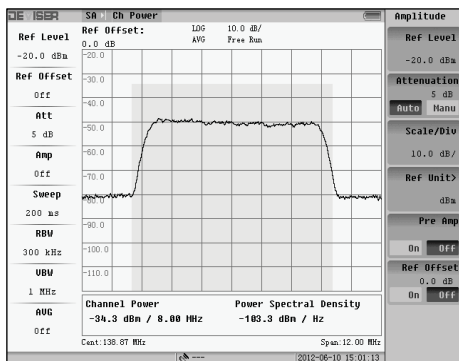

Fig. 3-68 Amplifier OFF

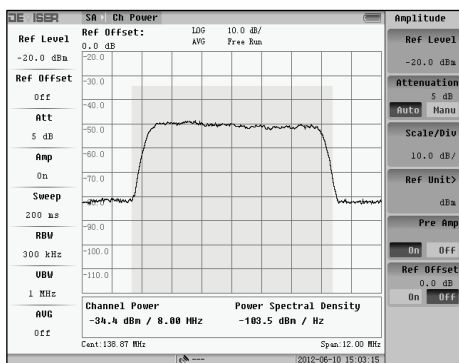

Fig. 3-69 Amplifier ON

(3) Scale/Div

The valid value of Scale/Div is integers from 1 to 40, and 9 number from 0.1 to 0.9. The default value is 10dB/grid. Decreasing the value, the waveform will be amplified, and it is easy to observe the waveform details. The following figure shows the result of 5dB/Div.

AD8000 Series Spectrum Analyzer Instruction

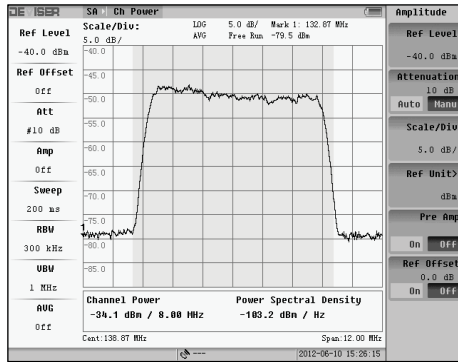

Fig. 3-70 Wave of 5dB/Div

(4) Ref Offset

If level offset is opened, the amplitude of waveform will be magnified and the channel power relative value will also be changed. The following figures show the measurement results under different conditions of the level offset.

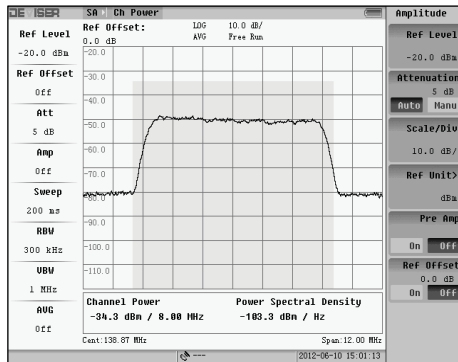

Fig. 3-71 Ref Offset OFF

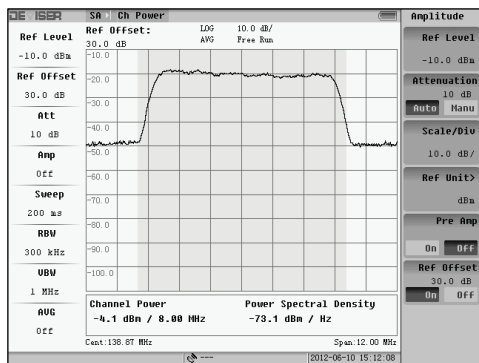

Fig. 3-72 Ref Offset 30 dB/

3.3.2 Basic Parameter Settings

The basic parameter setting is quite easy comparing with spectrum sweep. It is only related to the setting of video average and scan type. Other parameters such as resolution BW, VBW, sweep time and etc. are configured by system, not changeable.

The basic parameter settings is implemented through **CPL** key. Press the key, and the following menu would pop up.

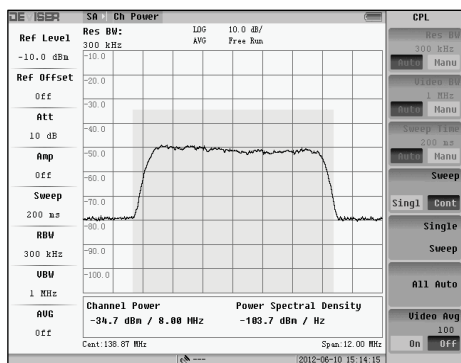

Fig. 3-73 Basic Parameter Settings

The setting of basic parameter of channel power and the function are the same as spectrum sweep type.

3.3.3 Measurement Parameter Setting

Press the **MEAS** key to set some special function when measuring.

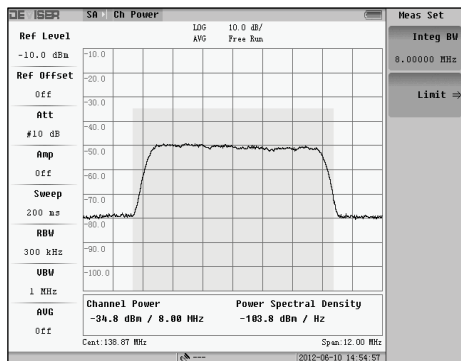

Fig. 3-74 Channel Bandwidth Setting

1 Channel BW

After selecting the centre frequency, users can set the channel BW by inputting the frequency manually. The default channel BW is 8MHz. In order to measure accurately, the span frequency is set to 1.5 times of the channel BW.

Press the channel BW soft-key to change the value. The default value is 8MHz. Channel bandwidth is proportional to span. Therefore, span will be changed according to channel BW value. The channel bandwidth can also be changed by digital inputs, up/down key and knob.

2 Limit

The main contents of Channel power includes channel power and power density, so there are the limits of channel power and power density.

Limit is set as the figure below. Press the soft key of the limit, and the following dialog box will pop up. The master switch controls all limit measurement. When turning off, all settings are not editable, shown as below:

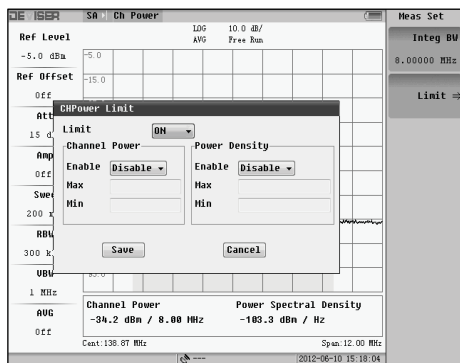

Fig. 3-75 Master Switch of Limit OFF

Only when the master switch and one of the measurement limit switches are turned on, the limit measurements can be measured and set.

The limit settings dialog box is shown as below after turning on the limit.

AD8000 Series Spectrum Analyzer Instruction

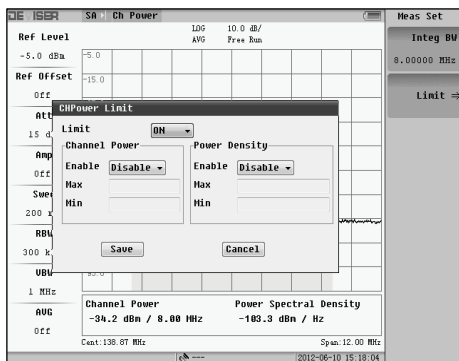

Fig. 3-76 Limit Setting

There are upper and lower limit settings for limit of Channel power and power bandwidth. The focus could be moved with the knob or the up/down keys to the dialog box which needs to be edited. Press the Enter key to edit. Input number with number keys. The default unit is the unit of current amplitude. Confirm input by soft-key or enter key.

If the limit measuring is enable, and the value is between the upper and lower limits, it is qualified and marked by green character, otherwise it is unqualified marked by red characters. If the limit is not enabled, the result is still displayed in white characters. The result of limit on the top of the screen is the comprehensive test result. As long as there is a failure of limit, the combined result was not qualified.

3.3.4 Basic Usage

Basic usage refers to marker and peak functions.

1 Marker Function

After pressing **MARK** key, the following menu will pop up. It is only about normal marker and delta marker. The theory is the same as Swept SA.

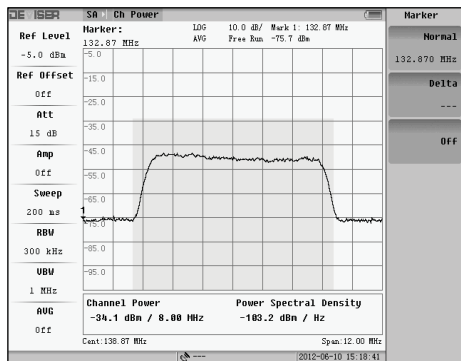

Fig. 3-77 Marker Menu

2 Peak Function

Press **PEAK** key, the following menu will pop up.

Peak function includes next peak, next left peak, next right peak, peak track, track type, peak-peak, minimum value and etc. Please refer the relevant introduction in swept SA.

AD8000 Series Spectrum Analyzer Instruction

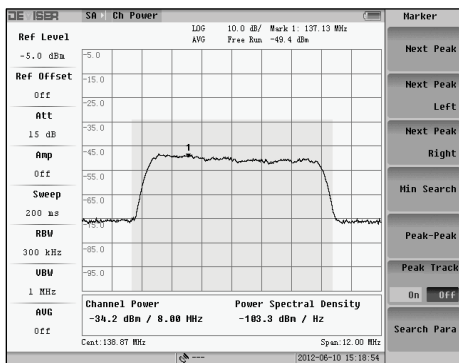

Fig. 3-78 Peak Menu

3.3.5 Slot Signal Basic Parameters Settings

The operations of frequency and amplitude of Burst RF and continuous RF measurement are the same.

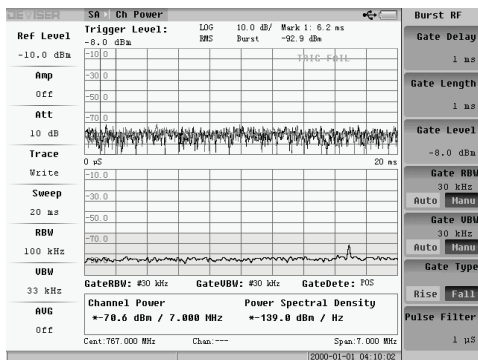

Fig. 3-79 Burst RF Channel Power Interface

The setting of burst RF basic parameters is also set with **CPL** key. The Sweep Mode and Trigger should be noticed. Sweep mode only includes 'no FFT' mode, and the default of Trigger is trust RF. If you choose the free triggered, it would lead to Burst RF into the Continuous RF.

3.3.6 Slot Signal Measurement Setting

The difference between Burst RF measurement setting and Continuous RF is the Burst RF settings. The measurement parameter is to use **MEAS** **SETUP** key. Press burst RF signal settings to enter the sub-menu as the figure below:

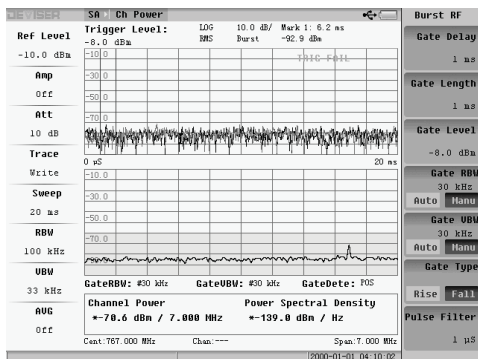

Fig. 3-80 Slot Signal Setting Menu

(1) Gate Delay

The gate delay setting is the position of the green box in the figure. There is a wave diagram of a time domain in the box. The frequency domain diagram, which is the spectrum diagram of the wave inside the green box is below.

(2) Gate Length

The setting of gate length is the width of domain cutting-out wave.

(3) Trigger Level

Adjust the trigger level. A red line on the screen represents the value of the trigger level. When the trigger level is large/small enough, circumstance of figure 3-34 would appear. A 'TRIG FAIL' sign means trigger fails, and the wave is gray. The gray wave is real wave. The yellow wave represents the wave of trigger succeeding. If the trigger fails, the yellow wave could not detect spectrum of selected burst. Adjust the trigger level, which is the red line. When the red line reaches the peak of the gray wave, trigger succeeds, and the gray signal disappears.

AD8000 Series Spectrum Analyzer Instruction

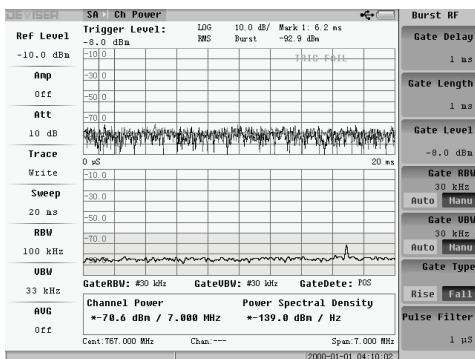

Fig. 3-81 Trigger Fails

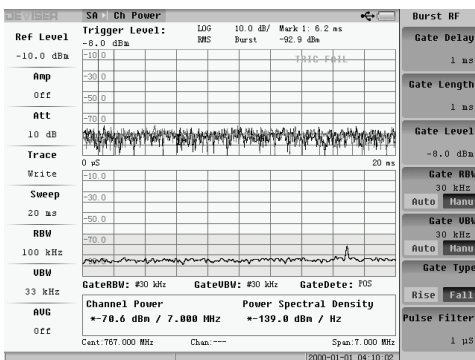

Fig. 3-82 Trigger Succeeds

(4) Gate RBW

The gate RBW setting is to set the spectrum RBW of selected wave.

(5) Gate VBW

The gate VBW setting is to set the spectrum VBW of selected wave.

(6) Trigger Type

The trigger type is divided into raising and falling trigger.

3.4 Adjacent Channel Power

The adjacent channel power mainly measures the changing range of the power of adjacent channels and current channel. The bandwidth of adjacent channel is the same as the bandwidth of the current tested channel.

Select adjacent channel power measurement type, and the following menu would pop up. Because of the difference in measurement signal, the carrier wave bandwidth, adjacent channel bandwidth, number of carrier wave and number of adjacent channel would be different. This device could measure up to 12 carrier waves and 6 pairs of adjacent channel.

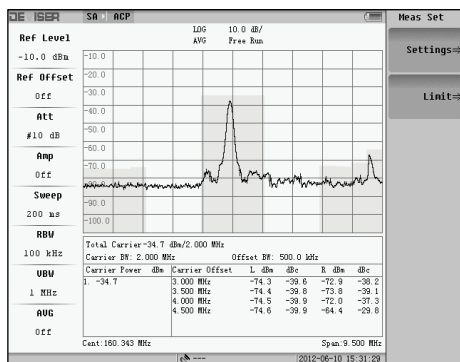

Fig. 3-83 Adjacent Channel Power

3.4.1 Basic Measurement

1 Frequency

Press the **FREQ** key, and the Adjacent Channel Power spectrum menu as the figure below will pop up. The center frequency and frequency step of the adjacent channel power measurement could be set with the menu. The method is the same as it in spectrum sweep measurement type.

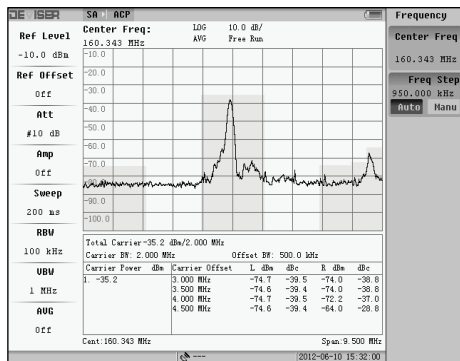

Fig. 3-84 Adjacent Channel Power Frequency Menu

2 Amplitude

Press the **AMPTD** key, and the follow menu will pop up.

The default status of 'Auto Level' is on. When the input signal fluctuates largely during measuring, the system will automatically adjust the attenuator and amplifier. Furthermore, the average power can also be used to smooth the results. If Auto level is off, users can change relevant amplitude parameters manually. Such as reference level.

AD8000 Series Spectrum Analyzer Instruction

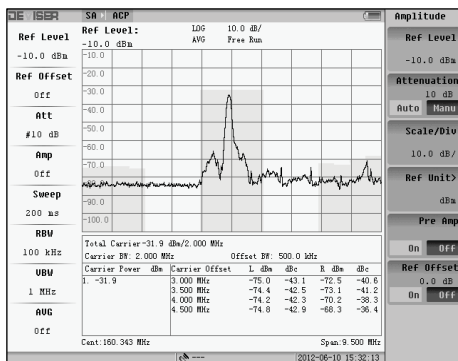

Fig. 3-85 Adjacent Channel Power Amplitude Menu

3.4.2 Basic Parameter Settings

The basic parameter settings of Adjacent Channel Power is same as channel power. It is only about the video average and scan type; other parameters such as RBW, VBW, sweep time and etc. are set by system default and unchangeable.

The setting of basic parameter is done with **CPL** key. Press the soft-key, and the following menu would pop up.

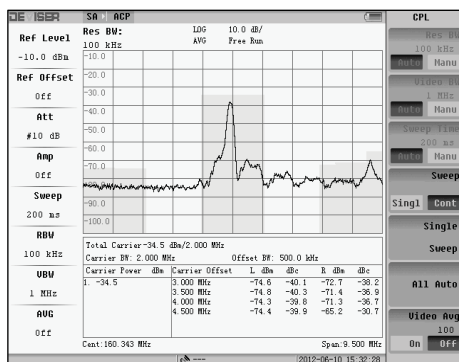

Fig. 3-86 Basic Parameter Settings

3.4.3 Measurement Parameter Settings

MEAS

The measurement parameter setting is done with **SETUP** key. Press the key, and the following menu which could be used to set some special functions of adjacent channel power would pop up.

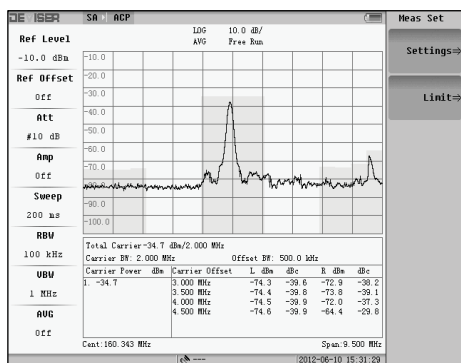

Fig. 3-87 Measurement Parameter Setting Menu

1 Parameter Setting

Press the soft-key, and the parameter setting dialog box will pop up. Set current focus with the knob, and the selected item is the current settable item. Drop down the menu or manually input to set the needed parameters, and then press 'OK' to save the settings and exit the dialog, 'Cancel' to cancel the settings and exit the dialog box.

AD8000 Series Spectrum Analyzer Instruction

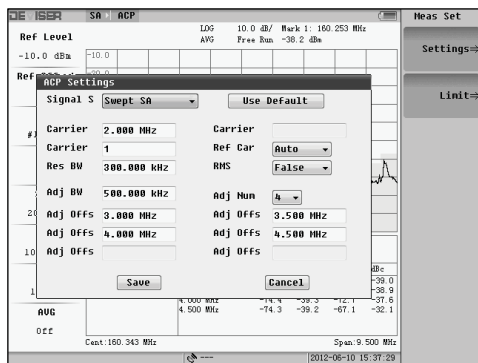

Fig. 3-88 Parameter Setting

All signal types of the device have default values. Generally the default value could be used to complete the most basic and important measurement. Selete 'Restore Default' to set all parameters in the signal back to the default value.

1 Limit

The limit setting is shown as below. Press the soft-key, and the dialog box would pop up.

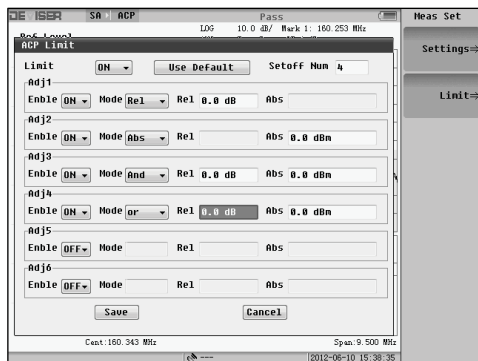

Fig. 3-89 Limit Setting

AD8000 Series Spectrum Analyzer Instruction

Turn off all adjacent channel limits with the master switch. To turn on certain adjacent channel, the master switch and its switch must be used together.

The limit of adjacent channel power includes absolute and relative limit. Absolutely limit is for the real power of adjacent channel; relative limit is about the differential power of adjacent channel and the carrier power. When the adjacent channel power is less than the absolute limit, it is absolutely qualified; when the relative value is less than the value of the relative limit, it is relatively qualified. Qualified, unqualified and not enable are marked by green, red and white.

Each pair of adjacent-channel limit has four models, absolute, relative, both and or.

Absolute mode: absolutely qualified is qualified

Relative mode: relatively qualified is qualified

Both mode: absolutely and relatively qualified is qualified Or

mode: either absolutely or relatively qualified is qualified

Only when both left and right adjacent channels are qualified, the pair of adjacent channel is qualified. The limit comprehensive result inspection shows whether all active adjacent channels are qualified. The comprehensive result is qualified only if all active adjacent channels are qualified in the selected mode. Qualified, unqualified and not enable are marked by green, red and white.

The function of 'Restore Default' key is the same as it in parameter setting, which is to set the limit to the default limit of the current signal.

Setting as figure 3-85, the measurement result of figure 3-86 could be gotten. There are 6 pairs of adjacent channel. 1 is relatively qualified, 2 is absolutely qualified, 3 is both qualified, and 4 is or qualified. Channel 5 and 6 are limit function turning-on and comprehensive measurement result qualified.

AD8000 Series Spectrum Analyzer Instruction

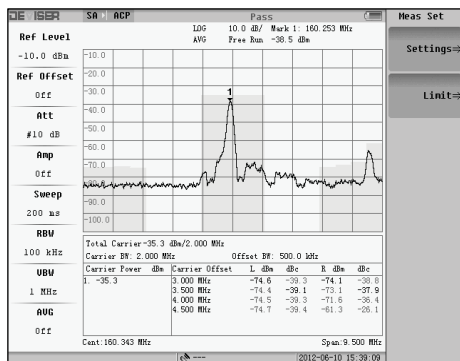

Fig. 3-90 Limite Measurement Result

3.4.4 Basic Usage

The basic usage mainly includes marker and peak function.

1 Marker Function

Press the **MARK** key, and the following menu would pop up. The functions only include normal and delta marker. The theory is the same as spectrum sweep.

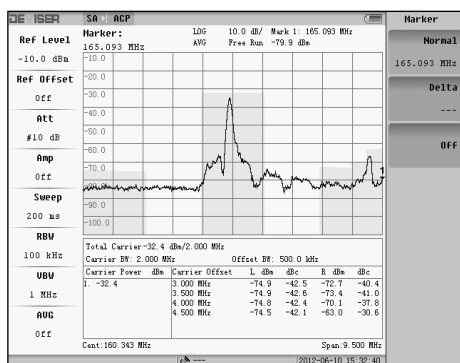

Fig. 3-91 Marker Menu

2 Peak Function

Press the **PEAK** key, and the menu of peak will pop up as the following figure.

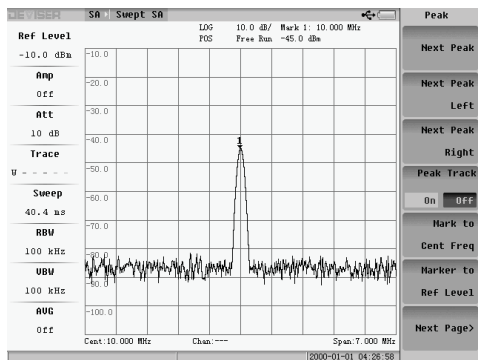

Fig. 3-92 Peak Menu

Peak function includes next peak, next left peak, next right peak, search condition, peak track, peak-peak, minimum value and etc. The theory is the same as spectrum sweep.

3.5 Occupied BW

The occupied bandwidth is to mainly measure the frequency range of certain percentage of the total power. In Channel Measurement Menu, user scan press the 'Setting' soft-key to modify the 'Channel Spacing' and 'Occupied Bandwidth %Power' manually. The default value of 'Channel Spacing' is 99.9%.

In Channel Measurement Menu, press the 'Occupied Bandwidth' soft-key, and the following menu will appear

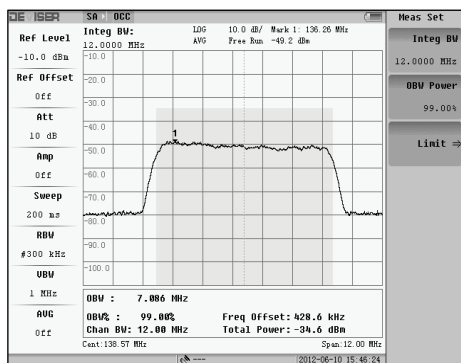

Fig. 3-93 Occupied BW

After collecting a group of data, the system would calculate the total power of the entire span frequency, and then find out the maximum point. The differential of the frequency of this point and the enter is the center offset. Set the maximum point of the center, expand the range to both sides till the range:

Total energy = total power x percentage of occupied BW

The found area is the occupied BW

The width with background in the figure represents the carrier bandwidth, the height indicates the carrier power, and the center dashed is the position of the current center offset.

3.5.1 Basic Measurement

1 Frequency

Press the **FREQ** key, and the following menu would pop up. The center frequency and frequency step of occupied BW could be set. The method is the same as setting it in spectrum sweep measurement.

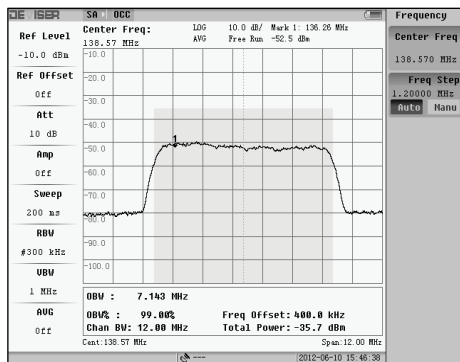

Fig. 3-94 Occupied BW Frequency Menu

AD8000 Series Spectrum Analyzer Instruction

2 Amplitude

After pressing the **AMPTD** key, the following menu would pop up.

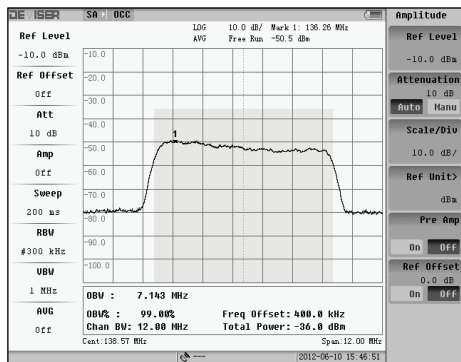

Fig. 3-95 Occupied BW Amplitude Menu

3.5.2 Basic Parameter Setting

The basic parameter setting of occupied BW is the same as channel power, only about the setting of video average and sweep mode. Other parameters such as RBW, VBW, sweep time and etc. are default, not changeable.

The setting of basic parameter is done with **CPL** key.

Press the soft key, and the following menu would pop up.

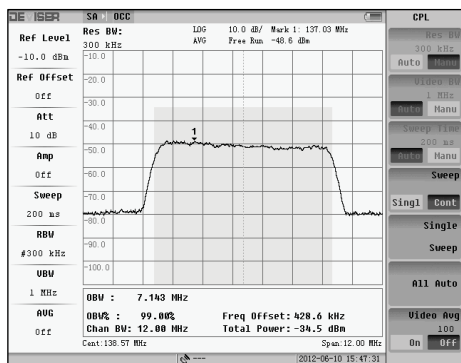

Fig. 3-96 Basic Parameter Setting Menu (Page 1)

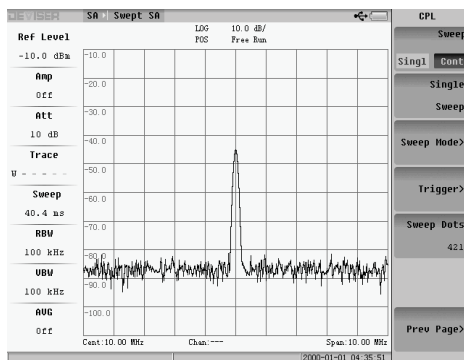

Fig. 3-97 Basic Parameter Setting Menu (Page 2)

3.5.3 Measurement Parameters Settings

Press the **MEAS** **SETUP** key, and the following interface which could be used to set some special function would pop up.

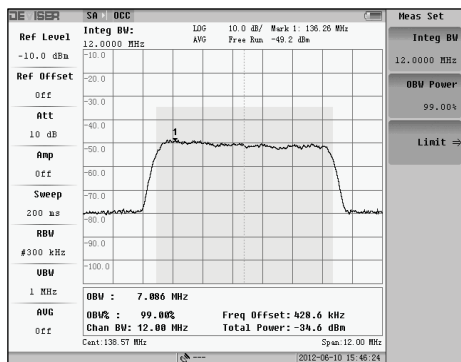

Fig. 3-98 Channel BW Setting

1 Channel BW

Press the 'Channel BW' key to change the value of channel BW. The default channel BW is 8MHz. The channel bandwidth is proportional to span. Therefore, span will be changed according to channel BW value. The channel bandwidth can also be changed by digital inputs, up and down key and knob.

2 Occupied Bandwidth %

Press the 'Occupied Bandwidth %' key to change the percent of Occupied Bandwidth. The default value is 99%. It can also be changed by digital inputs, up and down key and knob.

3 Limit

The setting of limit is shown as the following figure. Press the soft key, and the following dialog box would pop up.

AD8000 Series Spectrum Analyzer Instruction

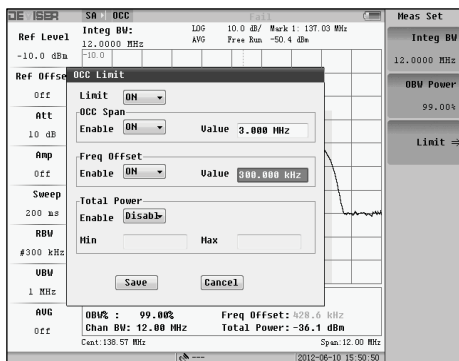

Fig. 3-99 Limit Setting

The limit of occupied BW includes 3 items. Users can enable the limit line and input the value with the limit dialog box.

Only if the master switch is on, all limit measurement value could be enabled and set.

When the limit value of occupied BW is the lower limit of occupied BW, and the value of occupied BW measurement is greater than the value, it is qualified.

When the limit value of center spectrum is the absolute value of the center-frequency offset, and frequency offset is less than the value, it is qualified.

When the value of channel power measurement is between the upper and lower limits, it is qualified.

The final result is passed only if all measurement items are qualified. Qualified, unqualified and disable are marked by green, red and white in color.

4 RF Signal & Slot Signal Setting

Press 'RF Signal' to choose the signal type: burst and continuous signal.

After choosing the slot signal, it should be set up. The method is the same as it of channel power.

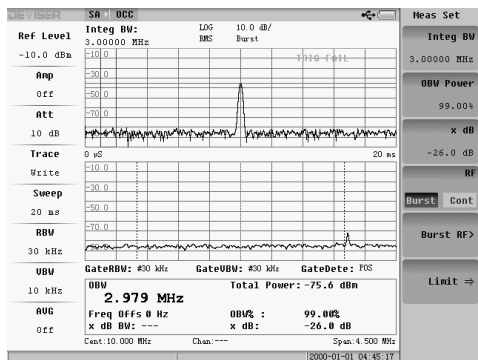

Fig. 3-100 Slot Signal Setting

3.5.4 Basic Usage

It is mainly about marker and peak function.

1 Marker Function

The figure 3-102 will pop up after pressing **MARK** key. It is only about normal mark and delta mark. The theory is same as spectrum scanning.

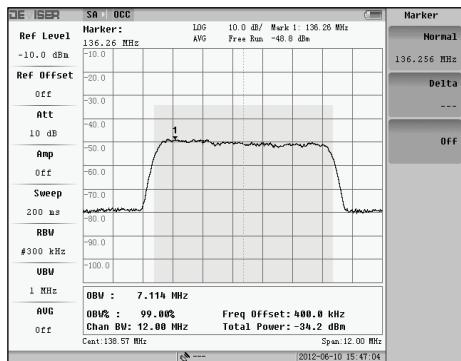

Fig. 3-101 Marker Menu

2 Peak Function

Press the **PEAK** key, and the menu will pop up as below.

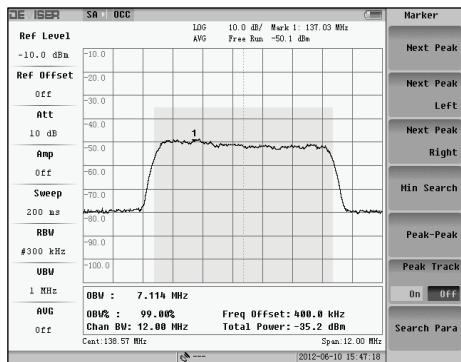

Fig. 3-102 Peak Menu

The peak function includes next peak, next left peak, next right peak, peak track, track type, peak-peak and minimum value. For details, please refer to explanation in Swept SA.

3.6 Field strength

The field strength measurement in swept SA mode is not the general measurement items of 'field strength meter'. The field strength meter is only a normal level measurement meter among measurement devices. The real field strength measurement refers to level measurement meter and the antenna. The unit is always dBuV/m. To choose the field strength measurement type, see the interface of figure 3-104

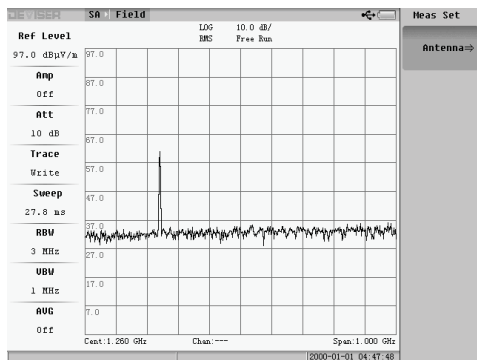

Fig. 3-103 Field Strength Measurement

Supported units:

dBm/ m², dBV/m, dBmV/m, dBuV/m, Volt/m, Watt/ m².

Calculation formula:

$$(E) \text{ dB}\mu\text{V}/\text{M} = (V_0) \text{ dB}\mu\text{V} + (AF) \text{ dB}/\text{M}$$

Electric field intensity E(V/m)

Power density S(W/ m²)

Value range with different unit:

	Min. (value)	Max. (value)
dBuV	-40	137
dBuV/m	-40+AF	137+AF

AD8000 Series Spectrum Analyzer Instruction

V/m	10 nV/m	7V/m
W/ m ²	10-8 error. No reference source nW/ m ²	1W/ m ²

3 methods of showing the antenna coefficient

Antenna gain Gain(G)[1/m], Antenna gain(g)[dBi], Antenna factor(AF)[dB(1/m)]

$$g = 10\text{dB} * \log_{10}(G); \quad AF = 20 * \log_{10}(f/\text{MHz}) - 29.7707\text{dB} - g$$

Basic measurement:

1, press **MEAS**, choose field strength measurement type, and the device would switch to field strength measurement mode.

2, press **Antenna** soft key, choose the antenna with up/downkey or knob, and press **ENTER**

Caution:

Users could choose antenna from the standard list of the device, or define users' antenna with the Workbench management software and put the information into the antenna list.

3, connect the antenna to the device

4, press the **FREQ** key, and set the center frequency and span. The span should be wide enough to cover the main channel bandwidth and up/down channel bandwidth.

5, press the **CPL** key to set the status of RBW and VBW into auto.

6, change the measurement unit with the **AMPTD** key. Press the **Unit** soft key to choose from dBm/m², dBV/m, dBmV/m, dBμV/m, Volt/m and Watt/ m².

7, press the **MARK** key to start to read the value of the marker.

3.7 FM/AM

Choose the FM/AM measurement in spectrum measurement, and enter the interface.

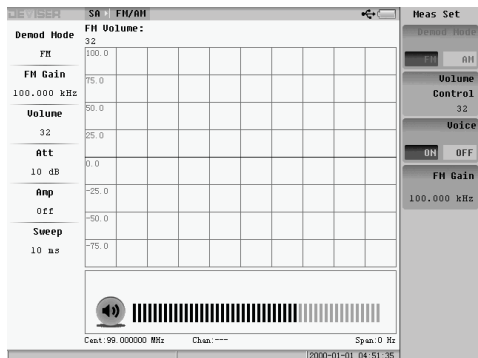

Fig. 3-104FM/AM Measurement

Basic measurement:

- 1, press **MEAS**, choose field strength measurement type, and the device would switch to field strength measurement mode.
- 2, make the current menu be the measurement setting, or press **MEAS SETUP** to enter the measurement setting. The default is FM measurement, which could be changed into AM measurement and the switch of audio output.
- 3, press the **FREQ** key, and set the center frequency, frequency step and the signal standard.
- 4, press the **CPL** key to set the track, sweep mode and sweep time.
- 5, press the **MARK** key to start to read the value of the marker.
- 6, press the **PEAK** key to set the peak value.

AD8000 Series Spectrum Analyzer Instruction

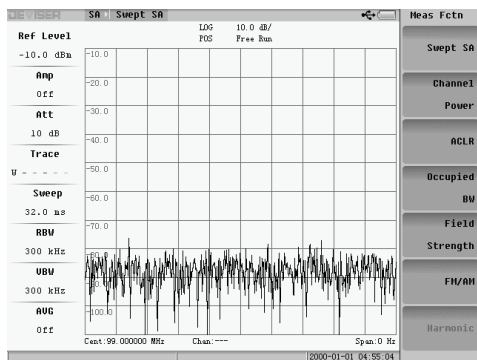

Fig. 3-105 AM Measurement

3.8 Harmonic Analysis

Choose the harmonic analysis measurement in spectrum measurement, and enter the interface.

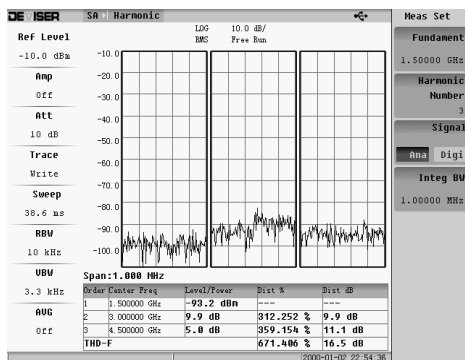

Fig. 3-106 Harmonic Analysis

Basic measurement:

1, press **MEAS**, choose field strength measurement type, and the device would switch to field strength measurement mode.

2, make the current menu be the measurement setting, or press **MEAS SETUP** to enter the measurement setting. It could set fundamental frequency, harmonic order, signal type and measurement bandwidth.

3, press the **FREQ** key, and set the center frequency, frequency step and the signal standard.

4, press the **CPL** key. The setting is almost the same as spectrum measurement. ,

5, press the **MARK** key to start to read the value of the marker.

6, press the **PEAK** key to set the peak value.

7, press the **AMP** key to set the amplitude.

4 Interference Analysis

Press the **MODE** button, select the interference analysis of measurement model, and following menu will pop up as figure 4-1

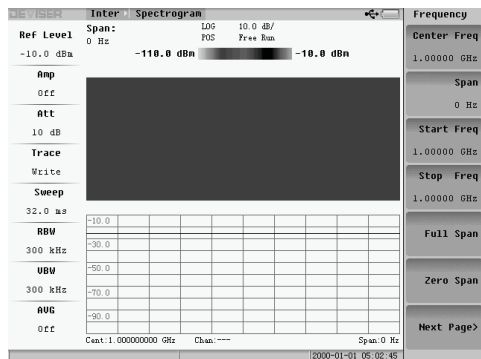

Fig. 4-1 Interference Analysis

The spectrum of the input signal of a period of time could be recorded in spectrogram in the interference analysis mode. It could measure the strength of the input signal, indicate the strength, analysis the signal ID and locate the interference.

4.1 Spectrogram

The spectrogram is a method of recording spectrum displaying in 3D: the x-axis indicates frequency while y-axis indicates time, and signal amplitude is represented by different colors. Users could analysis the time stability or find out intermittent interference signal with the spectrogram.

Press the spectrogram soft key, and the system will pop up menu shown as figure 4-2

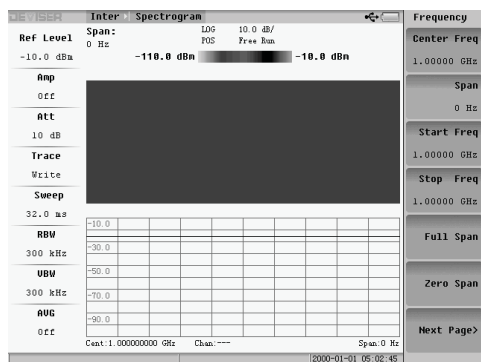

Fig. 4-2 Spectrogram

Press the soft key **Record** to can set period, Time Span, Data type, location and etc. The spectrogram file name would be the starting time of recording as 'Y-M-D-H-M-S' automatically.

Other settings such as frequency and amplitude are the same as before. **Display** is used to switch the two modes of spectrogram, spectrum diagram and full screen display spectrogram.

Peak Level and **Nadir Level** are used to set the maximum and minimum level of signal amplitude of current spectrogram. They could be set automatically or manually.

Press **Restart** to record the spectrogram again.

Press **Replay** to check the saved spectrogram files.

AD8000 Series Spectrum Analyzer Instruction

Press **Limit** to set the upper and lower limit to judge whether current signal is qualified or not. After turning on Limit, the spectrogram record type could be chosen as recording all spectrum or only recording unqualified data.

4.2 Signal Strength

Press the **MEAS** to select signal strength, and the measurement interface shown as figure 4-3 will pop up.

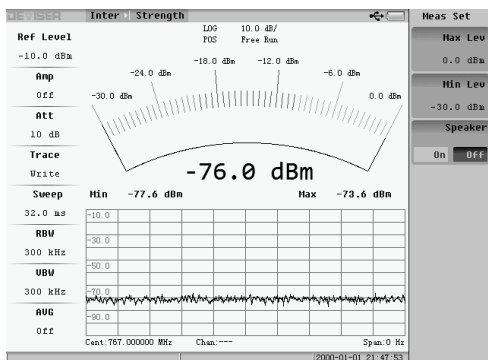

Figure 4-3 Signal Strength Measurement

The signal strength is used to measure dot frequency signal strength. The maximum scale and the minimum scale are used to set the range of current displayable signal strength. Turn on the sound in current signal strength display range, the frequency of the audio would increase as the signal strength increasing.

Press the **FREQ AMPTD CPL** function keys, and then we can do frequency, amplitude, and other basic settings.

4.3 Received Signal Strength Indicator (RSSI)

Press **MEAS**, select RSSI, and the following menu will pop up:

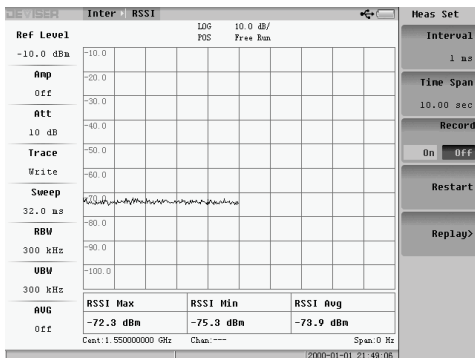

Fig. 4-4 RSSI

This function can implement recording a particular frequency point in time.

Press **Time Interval** to set the time interval of recording, min. 1ms; max. 100s.

Record Period is used to set the time of recording, min. 10ms; max. 10 days..

Press **record** to start recording. After record completing, the system would name the file as 'Y-M-D-H-M-S' automatically.

Replay is used to choose the history file to replay. The starting/ending time could be set. The replay menu is shown as figure 4-5:

AD8000 Series Spectrum Analyzer Instruction

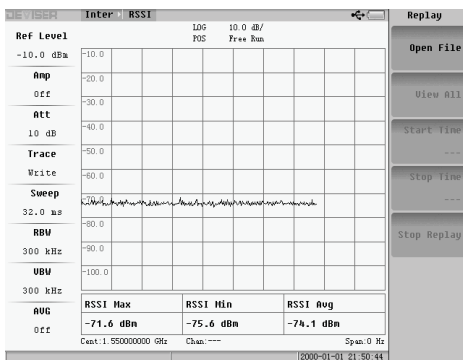

Fig. 4-5 Signal Strength Replay

4.4 Channel Sweep

Press **MEAS**, select channel sweep, and the measurement interface of shown as figure 4-6 will pop up:

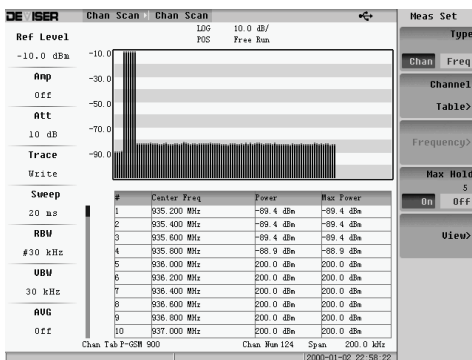

Fig. 4-6 Channel Sweep Mode

Press **PEAK**, **AMPTD** and **CPL** function keys to set peak, amplitude, frequency and other basic settings separately.

4.5 Interference localization

Press **MEAS**, select Inter Location, and the measurement interface would will pop up as figure 4-7:

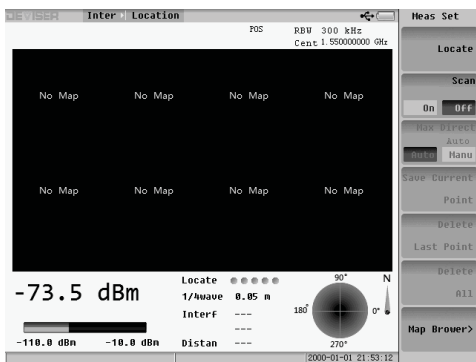

Fig. 4-7 Interference Localization Mode

Localization could be implemented for ma viewing after installing GPS in the spectrum analyzer.

Press **FREQ AMPTD CPL** to set frequency, amplitude, and other basic Setting.

4.6 Difference Spectrum

Press **MEAS**, select difference spectrum, and the measurement interface would pop up as figure 4-8:

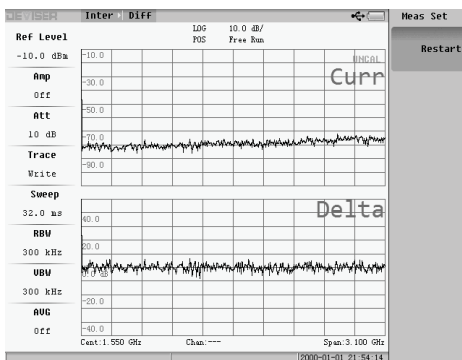

Fig. 4-8 Difference Spectrum Mode

Press **PEAK**, **AMPTD**, **MARK** and **CPL** keys to set peak, amplitude, frequency and other basic settings separately.

4.7 Signal ID

Press **MEAS**, select signal ID, and the measurement interface would will pop up as figure 4-9:

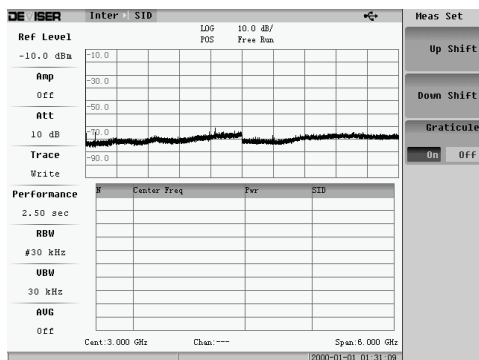

Fig. 4-9 Signal ID Mode

Press **FREQ**, **PEAK**, **AMPTD**, **MARK** and **CPL** keys to set frequency, peak, amplitude, frequency and other basic settings separately

5 Base Station Test

Press **MODE**, and then corresponding soft key of base station test to enter the measurement menu, shown as the following figure:

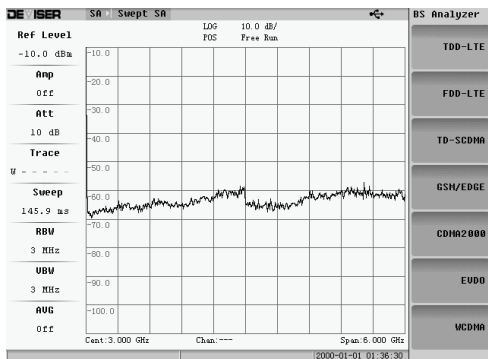

Fig. 5-1 Base Station Test Menu

5.1 TDD-LTE

Select TDD-LTE soft key to enter the menu, shown as the following figures

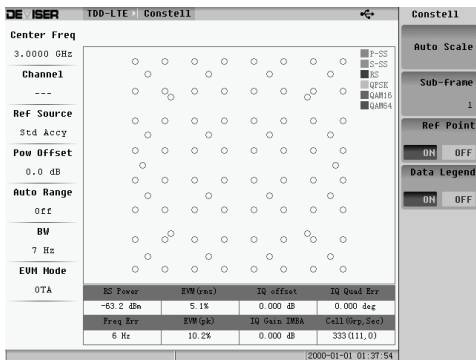

Fig. 5-2 constell Menu

5.1.1 Power vs. RB

Press the Pow vs RB soft key to enter the operation menu of Pow vs RB, shown as the following figure:

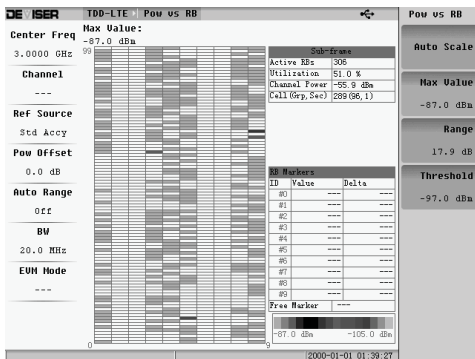

Fig. 5-3 Pow vs RB Menu

The measurement display includes power & RB grid, RB color map, measurement data form and measurement process bar.

The level of RB power color image is decided by the maximum value and range of RB color image. Those values could be set through entering manually or auto-defined color image.

AD8000 Series Spectrum Analyzer Instruction

1) Auto-Range

Select 'Auto-Range', and the color image of RB power would show.

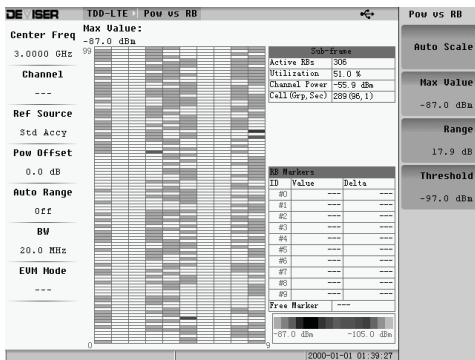

Fig. 5-4 Auto RB Power Color Image

2) Max. Value & Range

Select 'Max. Value' or 'Range' to set the parameter of RB power color manually. Different RB power color image are available.

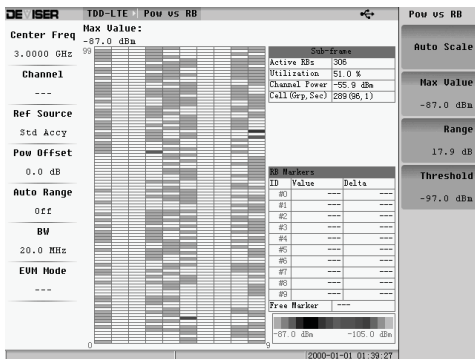

Fig. 5-5 Set RB power color image manually

The RB grid at the left of the spectrum shows the color of each RB PDSCH. The y-axis is frequency (subcarrier), and x-axis is time (subframe).

The form at the upper right of the spectrum is the measurement data form, including Active RBs, Utilization, channel power and Cell recognition.

The RB tag at lower right is used for power and RB measurement, describing selected RB. Specific RB sub-carrier/subframe coordinate higher than 2D grid would show as the power level.

5.1.2 Constellation

Select 'Constell' to enter the menu as the following figure:

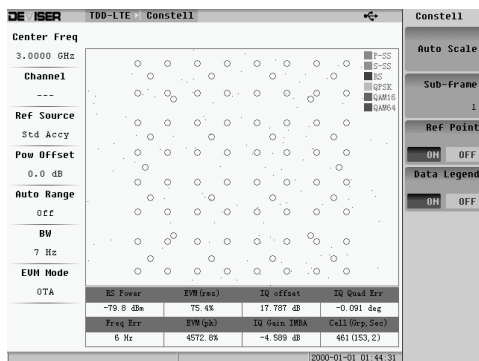

Fig. 5-6 Constellation Menu

This measurement shows demodulation symbol of constellation in first holder. It includes RS Power, EVM (rms), Freq Error, Carrier Frequency, SS Power, EVM (peak), Freq Error (ppm), and Cell.

- 1) Legend
- 2) Press the corresponding soft-key to set the status of Legend display.

AD8000 Series Spectrum Analyzer Instruction

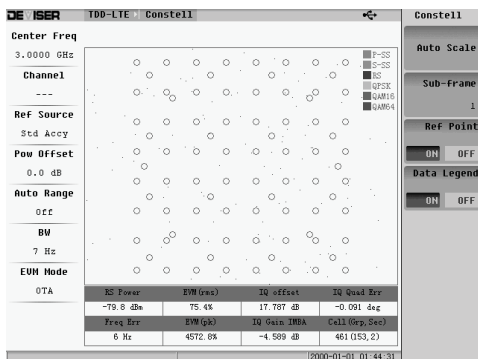

Fig. 5-7 Legend ON

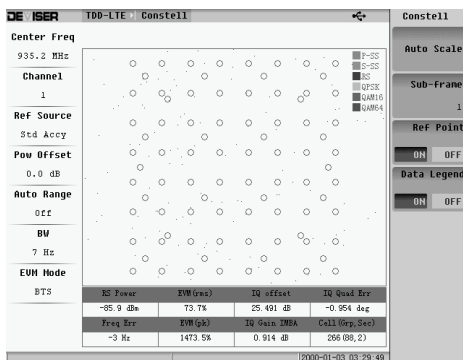

Fig. 5-8 Legend OFF

5.1.3 Control CH Power

Select 'Control CH Power' to enter the menu of control channel power.

The measurement shows the control channel power of key physical layer and 'constellation' in the measurement result.

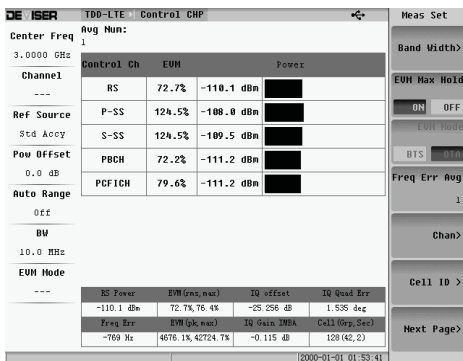

Fig. 5-9 Control Channel Power Menu

1) Bandwidth

Select 'Bandwidth' to enter. It include 6 frequencies: 1.4, 3, 5, 10, 15 and 20MHz.

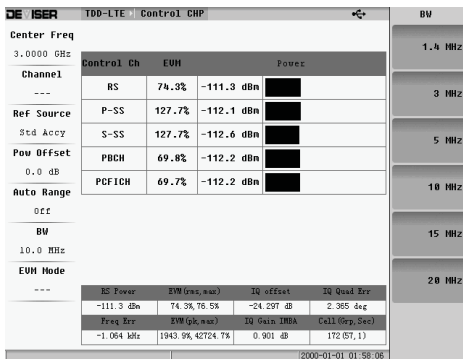

Fig. 5-10 Bandwidth

AD8000 Series Spectrum Analyzer Instruction

2) EVM Max. Hold

Press 'EVM Max. Hold' to turn on/off the EVM Max. Hold.

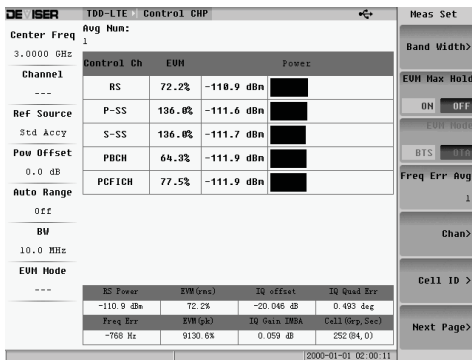

Fig. 5-11 EVM Max. Hold OFF

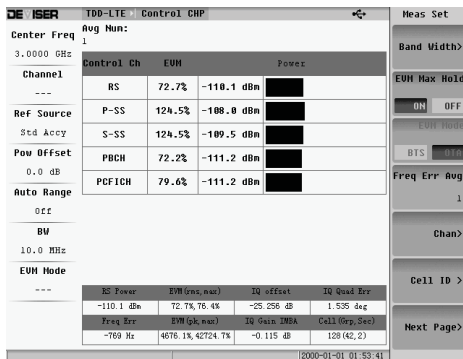

Fig. 5-12 EVM Max. Hold ON

3) EVM Mode

Users could select EVM mode which is divided into aotu and PBCH.

4) Freq Err Avg Cnt

The value could be set after selecting

AD8000 Series Spectrum Analyzer Instruction

5) Antenna Selection

Press to enter the sub-menu of antenna selection.

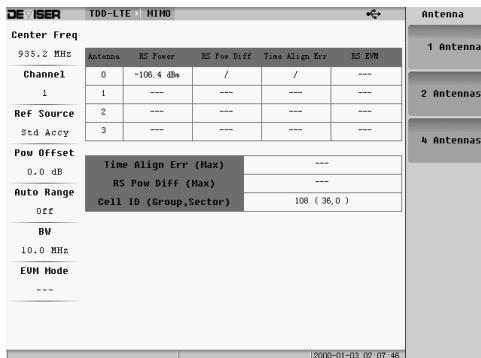

Fig. 5-13 Antenna Selection

6) Threshold

Press 'Threshold' to enter the setting menu with 2 choices, 'Threshold 1' and 'Threshold 2'. Press the corresponding key to set it.

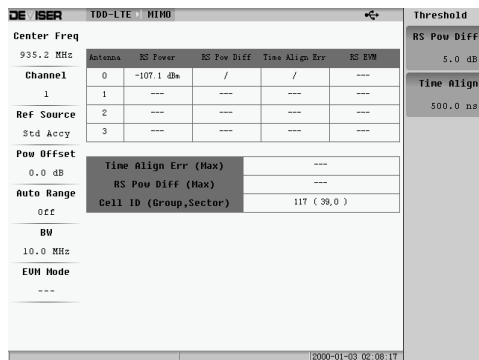

Fig. 5-14 Threshold Setting

5.1.4 Summary

Modulation summary shows Ref Signal (RS) Power, Sync Signal (SS) Power, EVM (rms), Freq Error (Hz and ppm), Cell ID and PBCH Power. It refers to the detail information of each measurement.

5.1.5 Scanner

There are 6 Cell Ids and measurements in scanner measurement.

The menu is as below:

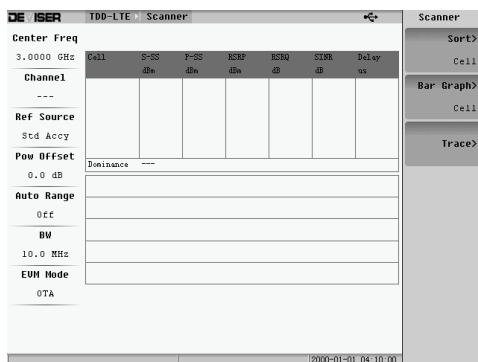

Fig. 5-15Scanner Menu

AD8000 Series Spectrum Analyzer Instruction

1) Sort

Select sort and select showing sort of measurement result. The selected numbers order from small to large.

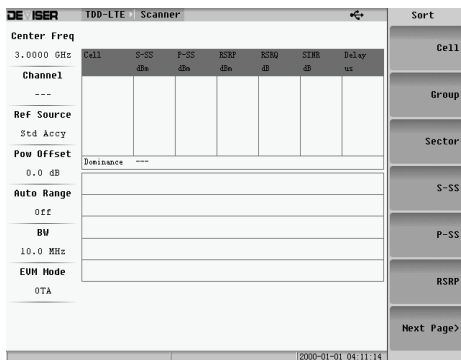

Fig. 5-16 Selection of Sort (Page 1)

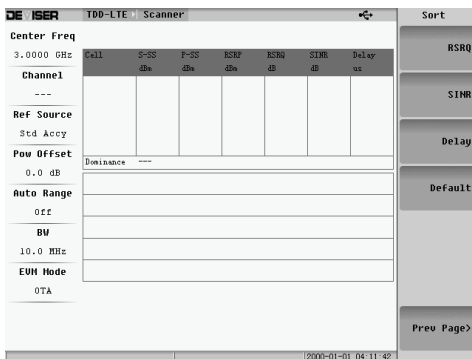

Fig. 5-17 Selection of Sort (Page 2)

AD8000 Series Spectrum Analyzer Instruction

2) Modulation Result

Select 'modulation result' to set its status.

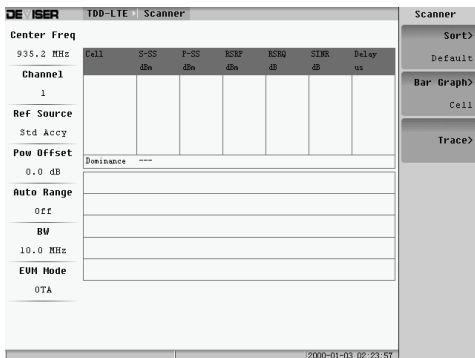

Fig. 5-18 Modulation Result

3) Bar Graph

Select 'Bar >' to enter the submenu of bar graph, shown as figure 5.22.

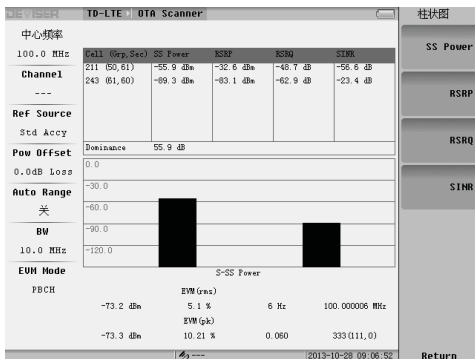

Fig. 5-19 Bar Graph Submenu

Press the corresponding softkey. Select the needed measurement value, and then the spectrum would show the bar graph of the selected measurement value.

AD8000 Series Spectrum Analyzer Instruction

4) Auto Save

Press the corresponding softkey to turn on/off the auto save function of LET scan file.

5.1.6 Channel Power

'Channel Power' is on the second page of TD-LTE menu as the following figure.

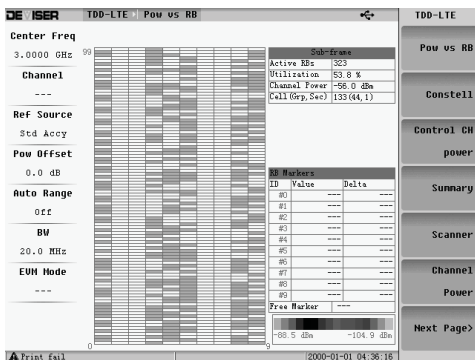

Fig. 5-20TD-LTE Menu Page 2

Press the 'Channel Power' soft-key to enter the submenu.

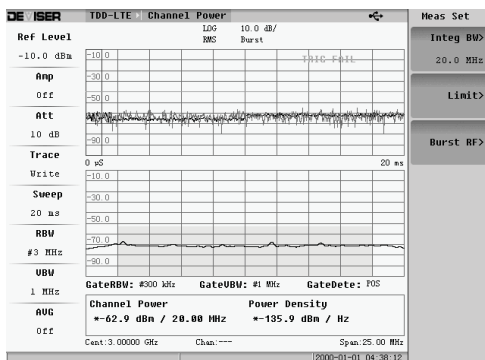

Fig. 5-21Channel Power Menu

The operations of 'Channel Power' in TD-LTE mode and spectrum measurement are almost the same. Please refer to '3.3 Channel Power'.

5.1.7 Occupied Bandwidth

Press the soft-key of 'Occupied BW' to enter the submenu:

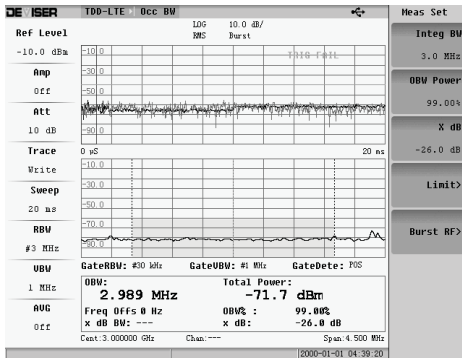

Fig. 5-22 Occupied BW Submenu

The operations of 'Occupied BW' in TD-LTE mode and spectrum measurement are almost the same. Please refer to '3.5 Occupied Bandwidth'.

5.1.8 Power vs.Time

Press the soft-key of 'Pow vs.Time' to enter the submenu as figure 5.29.

'Power vs.Time' shows the frequency of received signal in time domain.

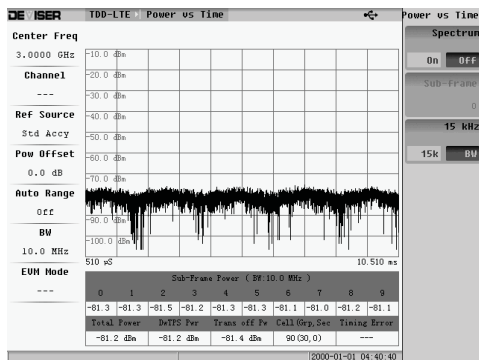

Fig. 5-23 Power vs.Time Menu

1) Subframe Spectrum

Press the soft key of 'Subframe Spectrum' to turn on/off the subframe spectrum.

2) Subframe Spectrum No.

If the subframe spectrum is off, the subframe spectrum number button is gray which means it is not available. It could only be done when the subframe spectrum is on.

Press the soft key of 'Subframe Spectrum No.' to enter it. The range is 0~9.

AD8000 Series Spectrum Analyzer Instruction

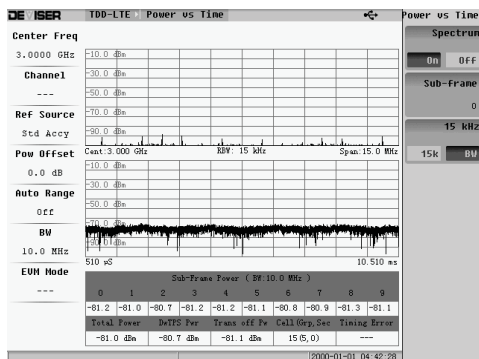

Fig. 5-24 Subframe Spectrum On

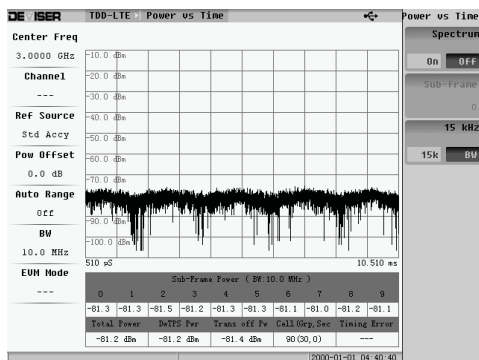

Fig. 5-25 Subframe Spectrum OFF

5.1.9 ACLR

Press the soft-key of 'ACLR' to enter submenu as figure 5.32.

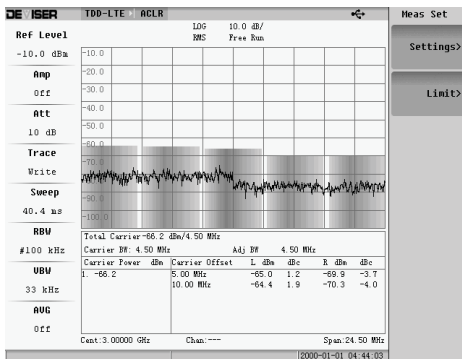

Fig. 5-26 ACLR

Select 'Parameter Setting' and 'Limit' in measurement setting, a window would pop up for setting up.

Press **FREQ**, **PEAK**, **AMPTD**, **MARK** and **CPL** keys to set frequency, peak, amplitude, marker and other basic items.

5.1.10 Co-Channel Interference

Press the soft-key of 'CCI' to enter the submenu as figure 5.33

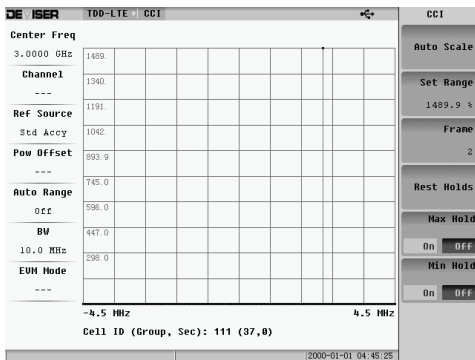

Fig. 5-27 Co-Channel Interference

Press **FREQ**, **PEAK**, **AMPTD**, **MARK** and **CPL** keys to set frequency, peak, amplitude, marker and other basic items.

5.1.11 Upstream Interference

Press the soft-key of 'Upstream Interference' to enter the submenu as figure 5.34.

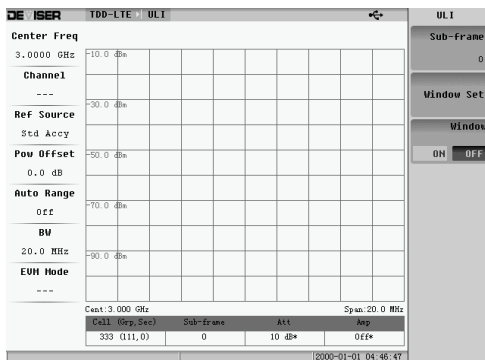

Fig. 5-28Upstream Interference

Press **FREQ**, **PEAK**, **AMPTD**, **MARK** and **CPL** keys to set frequency, peak, amplitude, marker and other basic items.

5.2 FDD-LTE

Press the soft-key of 'FDD-LTE' to enter the menu of FDD-LTE as the following figure:

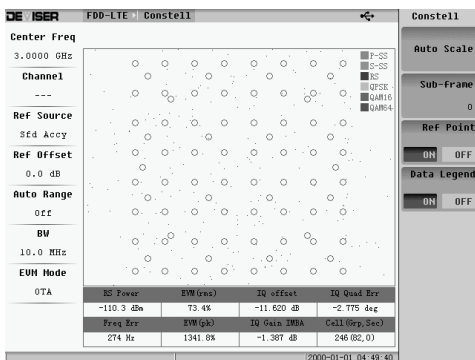

Fig. 5-29 TD-LTE Menu

5.2.1 Power vs RB

Press the Pow vs RB soft key to enter the operation menu of Pow vs RB, shown as the following figure:

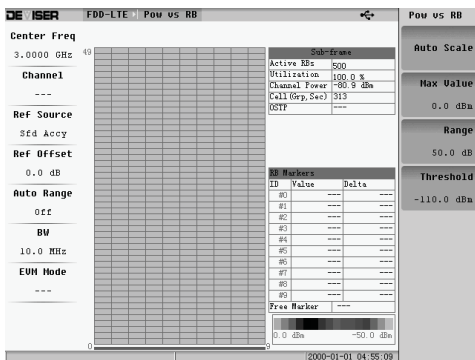

Fig. 5-30 Pow vs RB Menu

The measurement display includes power & RB grid, RB color map, measurement data form and measurement process bar.

The level of RB power color image is decided by the maximum value and range of RB color image. Those values could be set through entering manually or auto-defined color image.

1) Auto-Range

Select 'Auto-Range', and the color image of RB power would show.

AD8000 Series Spectrum Analyzer Instruction

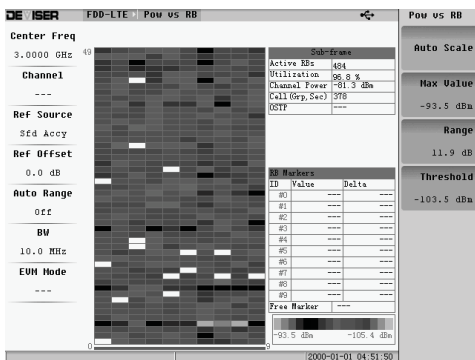

Fig. 5-31 Auto RB Power Color Image

2) Max. Value & Range

Select 'Max. Value' or 'Range' to set the parameter of RB power color manually. Different RB power color image are available.

The RB grid at the left of the spectrum shows the color of each RB PDSCH. The y-axis is frequency (subcarrier), and x-axis is time (subframe).

The form at the upper right of the spectrum is the measurement data form, including Active RBs, Utilization, channel power and Cell recognition.

The RB tag at lower right is used for power and RB measurement, describing selected RB. Specific RB sub-carrier/subframe coordinate higher than 2D grid would show as the power level.

5.2.2 Constellation

Select 'Constell' to enter the menu as the following figure:

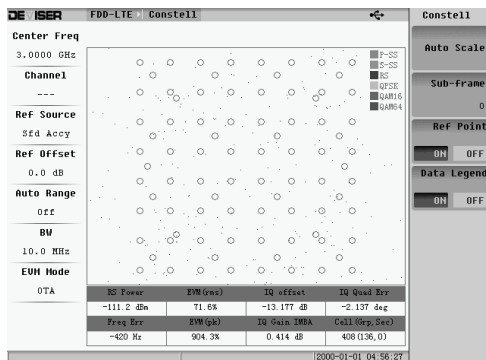

Fig. 5-32 Constellation Menu

The constellation operation in FDD-LTE is almost the same as it in TDD-LTE. Please refer to 5.1.2.

5.2.3 Control CH Power

Select 'Control CH Power' to enter the menu of control channel power.

The measurement shows the control channel power of key physical layer and 'constellation' in the measurement result.

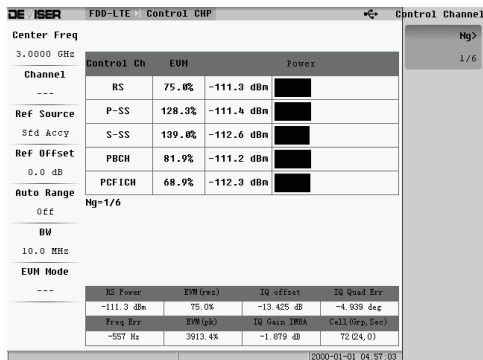

Fig. 5-33 Control Channel Power Menu

Press 'Ng>' in the home page to enter the Ng setting menu. 4 Ng values are available, 1/6, 1/2, 1 and 2.

Please refer to 5.1.3 for other operations.

5.2.4 Summary

Modulation summary shows Ref Signal (RS) Power, Sync Signal (SS) Power, EVM (rms), Freq Error (Hz and ppm), Cell ID and PBCH Power. It refers to the detail information of each measurement.

5.2.5 Scanner

There are 6 Cell IDs and measurements in scanner measurement.

The menu is as below:

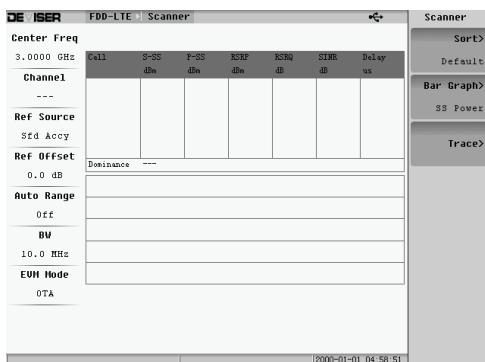

Fig. 5-34 Scanner Menu

The scanner operation in FDD-LTE is almost the same as it in TDD-LTE. Please refer to 5.1.5.

5.2.6 Channel Power

Press the soft-key of 'Channel Power' to enter the submenu.

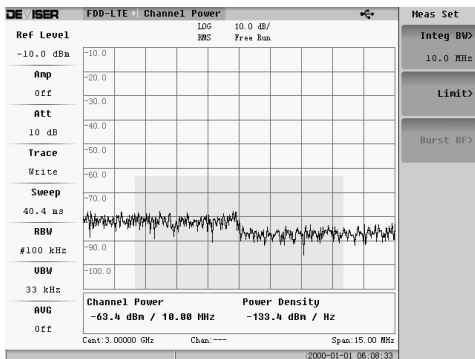

Fig. 5-35 Channel Power Menu

The operations of 'Channel Power' in TD-LTE mode and spectrum measurement are almost the same. Please refer to '3.3 Channel Power'.

5.2.7 Occupied Bandwidth

Press the soft-key of 'Occupied BW' to enter the submenu:

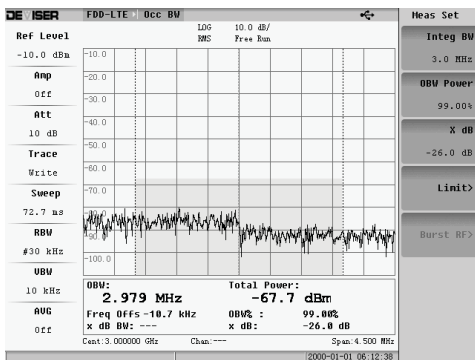

Fig. 5-36 Occupied BW Submenu

The operations of 'Occupied BW' in TD-LTE mode and spectrum measurement are almost the same. Please refer to '3.5 Occupied Bandwidth'.

5.2.8 ACLR

Select the 'ACLR' to enter submenu.

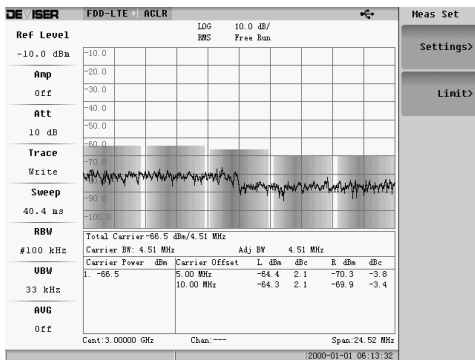

Fig. 5-37 ACLR

Select 'Parameter Setting' and 'Limit' in measurement setting, a window would pop up for setting up.

Press **FREQ**, **PEAK**, **AMPTD**, **MARK** and **CPL** keys to set frequency, peak, amplitude, marker and other basic items.

5.2.9 Co-Channel Interference

Press the soft-key of 'CCI' to enter the submenu

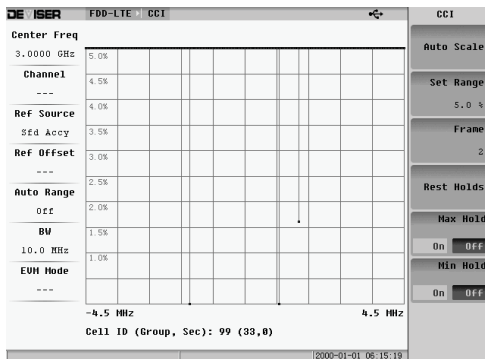

Fig. 5-38 Co-Channel Interference

Press **FREQ**, **PEAK**, **AMPTD**, **MARK** and **CPL** keys to set frequency, peak, amplitude, marker and other basic items.

5.2.10 SEM

Press the soft-key of 'SEM' to enter the spectrum template.

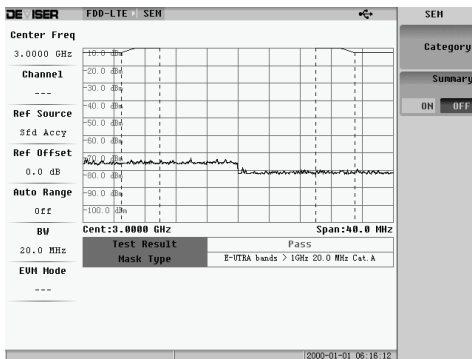

Fig. 5-39 SEM Spectrum Template

Select 'category' to select the template.

Select 'Summary' to turn on/off the measurement result display.

Press **FREQ**, **AMPTD**, and **CPL** keys to set frequency, amplitude, and other basic items.

6 Coverage Mapping

Press **MODE**, select the sof-key of Coverage Mapping to enter the menu shown as the following figure

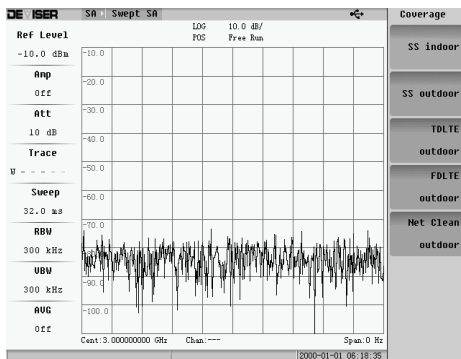

Fig. 6-1 Coverage Mapping Menu

6.1 Indoor Coverage

Select 'SS Indoor' to enter the indoor coverage function.

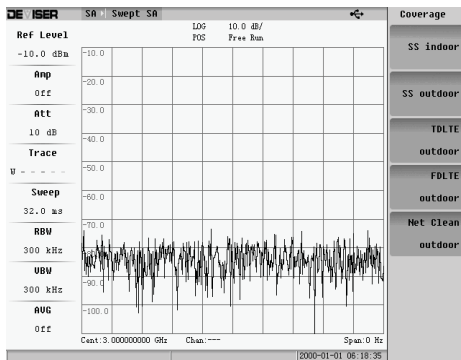

Fig. 6-2 Indoor Coverage Interface

- 1) Measurement status
- 2) buttons: start & end
- 2) Map viewing

If the map is larger than the screen, it could be moved.

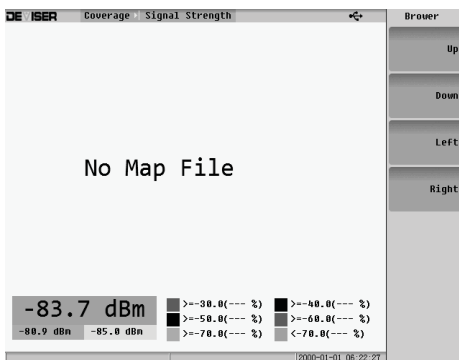

Fig. 6-3 Map Viewing

6.1.1 Measurement Setting

Press 'Meas SETUP' to enter the measurement setting menu.

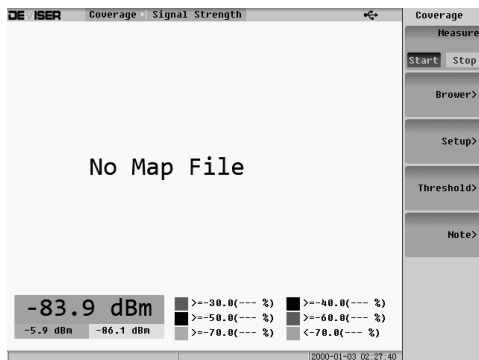

Fig. 6-4 Measurement Setting Menu

1) Limit

Select 'Limit' to enter the menu. There are 5 levels.

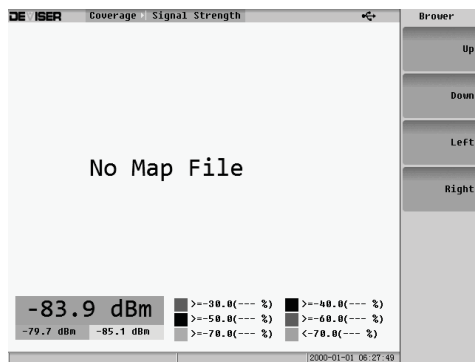

Fig. 6-5 Limit

2) Indoor Coverage Setting

Select 'Indoor Coverage Setting' to enter the submenu. Time measurement and free measurement are available. Time interval could be chosen in time measurement.

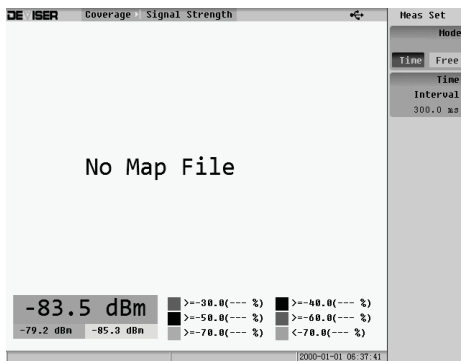

Fig. 6-6 Indoor Coverage Setting

3) Test Information

Test information submenu is used for entering information of the test including test person, location, test name and remarks.

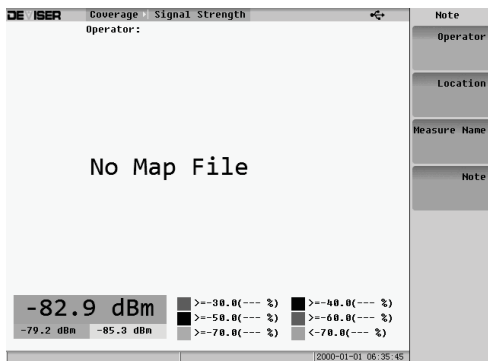

Fig. 6-7 Test Information

6.1.2 Coverage Measurement

There are 2 coverage measurements, time measurement and free measurement.

1. Time measurement

Mark at the corresponding location on the indoor map; mark again at another position. The data between two points are calculated by the time interval of two points.

- 1) Set the time interval first. The time range is from 100ms to 1min.
- 2) Ensure the measurement status is start.
- 3) Press Mark button; move the marker to the current position by selection 'Move Mark'. The x-axis and y-axis could be moved by selecting 'Move Direction'.

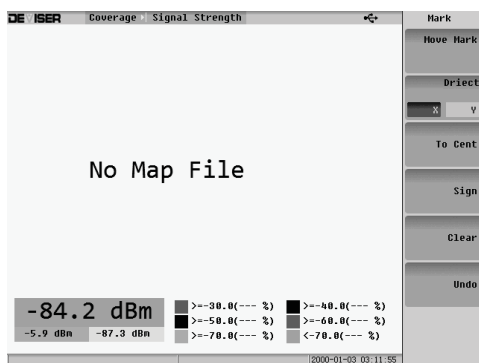

Fig. 6-8 Mark Menu

- 4) Press 'Mark', and the mark would change from blue to red.
- 5) Walk to the next position.
- 6) Press the mark button again at the next position, then the mark would change from red to blue, and it would generate measurement data.

AD8000 Series Spectrum Analyzer Instruction

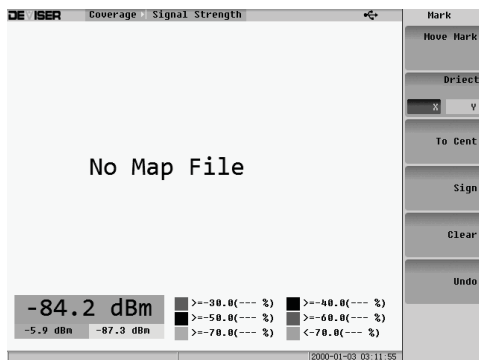

Fig. 6-9 Generate Time Measurement Data

- 7) Click on 'Clear All' to clear all measurement data on the map.
- 8) Click on 'Back' to clear the data between the current mark point and the previous one, which means 'back'.

2. Free measurement

Mark at the corresponding location on the indoor map; and make the current measurement data as the measurement data of the changed point.

- 1) Press Mark button, and move the marker to the current position by selection 'Move Mark'.
- 2) Press 'Mark' to show the measurement result on the map.

AD8000 Series Spectrum Analyzer Instruction

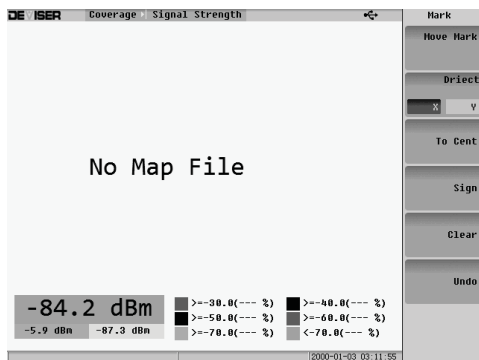

Fig. 6-10 Free Measurement Result

- 3) Click on 'Clear All' to clear all measurement data on the map.
- 4) Click on 'Back' to clear the data between the current mark point and the previous one, which means 'back'.

6.1.3 Save Measurement File

After the measurement completes, press 'Save', and the save menu would pop up. Select 'Measurement Result'.

Enter file name, and select saved format (data or CSV) and saved location (local or flash disk).

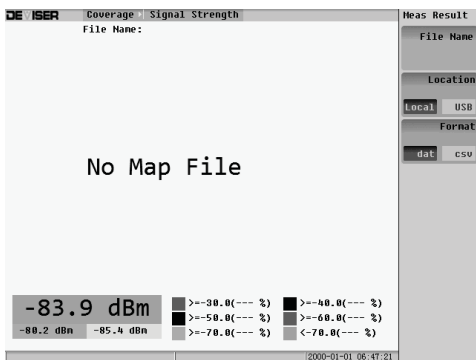

Fig. 6-11 Save Measurement Result File

6.1.4 Open Coverage File

When the measurement stops, press 'System', and the menu would pop up. Select 'File Management' then 'Measurement Result', and a dialog box of file selection would pop up.

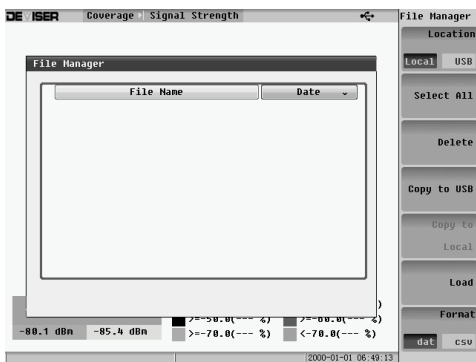

Fig. 6-12 Open Measured File

6.2 Outdoor Coverage

Select 'Signal Strength Outdoor' button to enter the function. The interface is as the following figure:

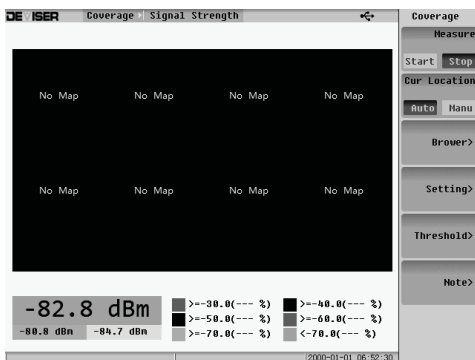

Fig. 6-13 Outdoor Coverage Interface

6.2.1 Coverage Measurement

1. Measurement Status

Enter the route coverage measurement function when it is not turned on. Click on the corresponding software to start/stop measuring.

2. Viewing Mode

There are two modes, satellite map and map. Press the button to switch between two modes.



Fig. 6-14 Viewing Map

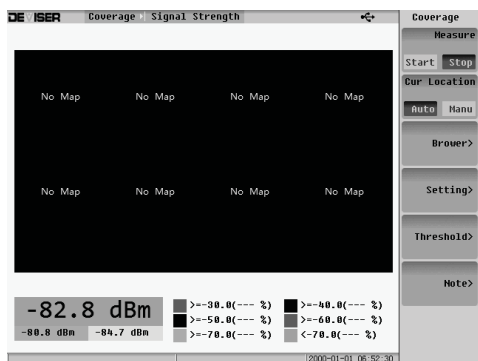

Fig. 6-15 Viewing Satellite Map

3. Current Location

The current location could be set as manual or auto.

If it is auto, the map would change as the GPS location moving; if it is manual, the map would be changed with the map Browse function.

4. Map Browse

It implements function of zooming in/out and moving the map.

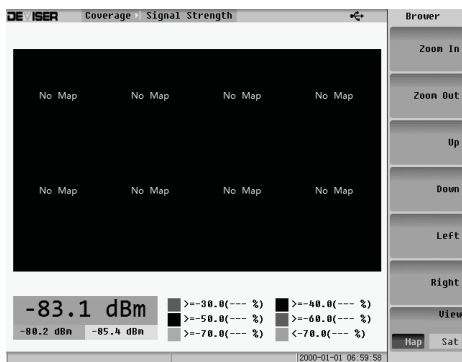

Fig. 6-16 Map Browse Mode

Attention: if 'Current Location' is auto, it would be switched to manual when using the map browse mode.

5. Limit

Press 'Meas Setup' button, and you could see the limit setting button. Click on the button to enter. There are 5 lines in total which means, A, B, C, D and F.

AD8000 Series Spectrum Analyzer Instruction

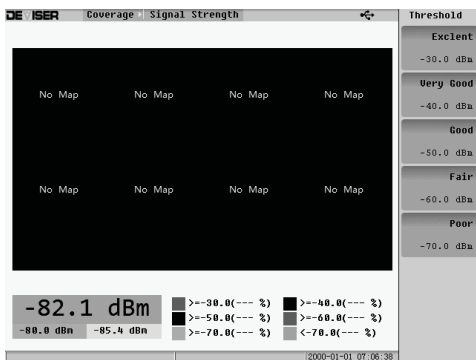

Fig. 6-17 Limit Selection

6.2.2 Save File

Press the “Save” key when the measure finishes. Select save measurement result to save the file.

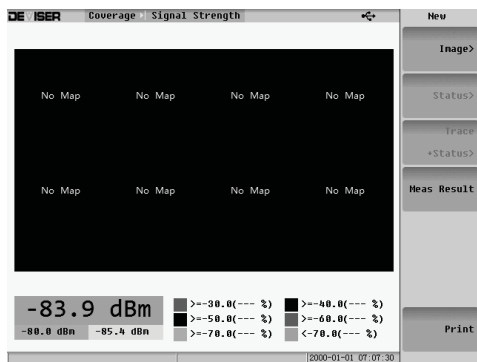

Fig. 6-18 Save Measurement Result File

The file could be saved as 3 types:

- ✧ Data: used for local replay
- ✧ CSV: data file, open in EXCEL (not supported currently)

AD8000 Series Spectrum Analyzer Instruction

- ✧ KML: used in Google Earth

AD8000 Series Spectrum Analyzer Instruction



Fig. 6-19 Measurement Result File Type

Select to save in local or U disk. Enter file name, and click on OK to save the data.

6.2.3 Open File

When the measurement stops, press 'System', and the menu would pop up. Select 'File Management'.

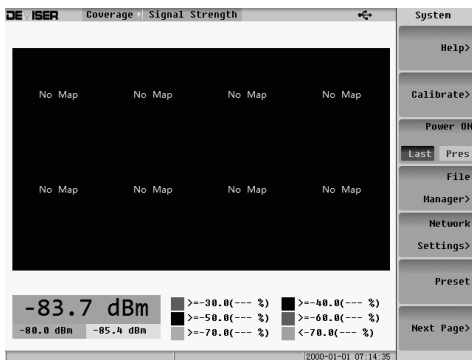

Fig. 6-20 System Menu

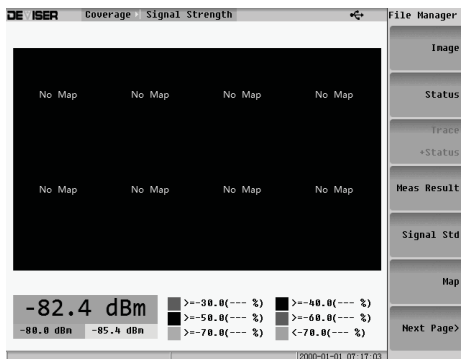

Fig. 6-21 File Management Menu

AD8000 Series Spectrum Analyzer Instruction

Select 'Measurement Result', and a dialog box of file selection would pop up as the figure below.

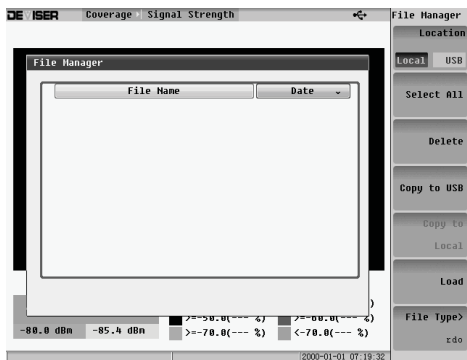

Fig. 6-22 Measurement File Selection Dialog Box

Select a file, and click on 'Load' to load the measurement file.

7 Tracking Source

After installing tracking source, transmission measurement could be done. Select 'Tracking Source' in the menu to enter the following interface.

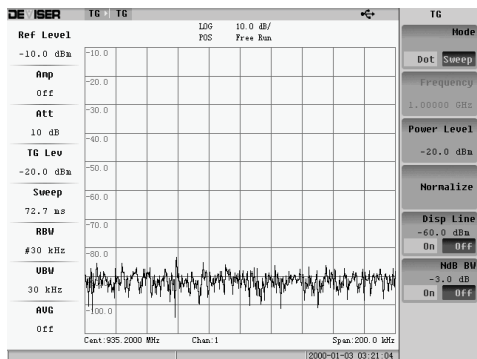

Fig. 7-1 Tracking Source Menu

To use tracking source function, the RF OUT port must be connected to the RF IN port.

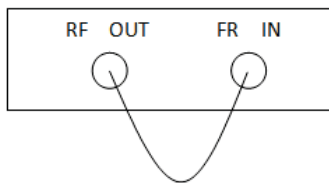

Fig. 7-2 Tracking Source Connection Line

After connection completes, turn on tracking source, and then press 'Tracking Source Amplitude' to change the output level with the number keys or knob. The level range is 0dBm ~ 50dBm.

The operation normalized also needs to connect the RF IN and OUT. The operation does not change the real output of the source, but only corrects the data with the software that makes the wave a straight line. When

AD8000 Series Spectrum Analyzer Instruction

parameters such as frequency, reference level, attenuator, source output amplitude and etc. change, the software correction fails automatically. The operation should be done again if necessary.

Multiple curves could be turned on through **Track**. Functions such as hold, maximum hold, minimum hold and erase could be chosen.

The amplitude of reference line could be adjusted with the up/down key and knob after pressing **Reference Line**.

The NdB bandwidth is used to measure the NdB bandwidth of current measured curve. It is generally used to measure the 3dB bandwidth of the filter.

8 File Operation

This chapter would mainly introduce following content:

- Save File
- File Management

8.1 Save File

Press 'SAVE' button, and the menu of figure 6-1 would pop up to save image, status, and track + status.

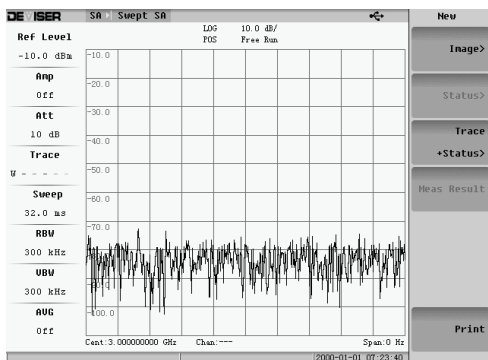

Fig. 8-1 SAVE Menu

Press **Image>** to save the current measurement wave as image in local or U disk. The image could be color or black and white. Shown as figure 6-2, in order to distinguish with normal display interface, the checking interface has a yellow block out of the image.

Press **status>** to save the current device status at local or U disk as figure 6-3. For instance, the current measurement type is spectrum sweep. Load in the status file of adjacent bandwidth measurement type named as 'acp', and then the device would start to measure the adjacent bandwidth. The parameter settings are the ones of loaded status file.

Press **Track + Status>** to save the current status and measurement track. The save type could be data or CSV shown as figure 6-4. The status and data of saved wave file would be loaded while the wave is checked. One field single sweep which is the same as single sweep in normal measurement would be shown, and the mark of single sweep would be shown at the upper right corner on the screen. To check the file after quitting, the sweep mode should be changed from 'signal' to 'continuous'. Then the instrument would measure continuously as the loaded status.

AD8000 Series Spectrum Analyzer Instruction

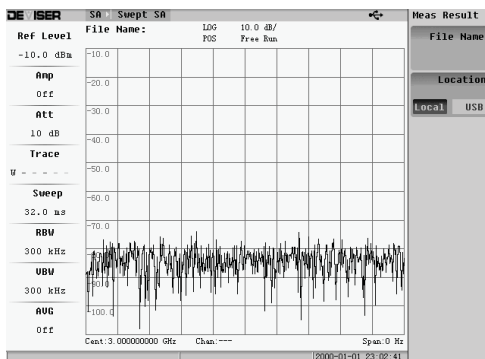

Fig. 8-2 Image Saving Menu

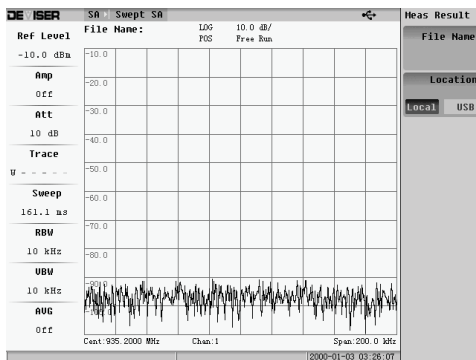

Fig. 8-3 Status Saving Menu

AD8000 Series Spectrum Analyzer Instruction

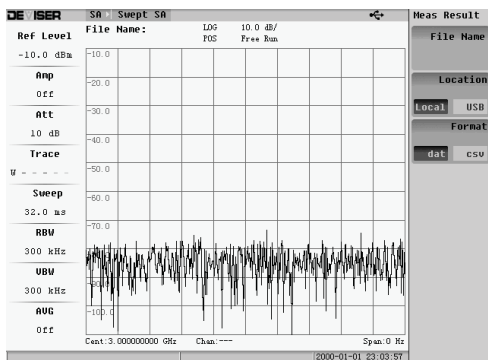

Fig. 8-4 Track + Status Menu

1 File Name

When the dialog box of creating new file pops up, the default cursor is at the place of entering file name. If file type and saving route do not need to be changed, file name could be entered and saved directly. In the process of saving file, the status information of 'Saving...' would show at the information area at the lower left corner of the dialog box shown as the following figure. The dialog box would close automatically after saving completing.

The file name could be digit and English letter (capital and small). Please refer to 2.2.4 for the input method.

2 Saving Route

Files could be saved locally or to any folder in USB. If there is no USB device, the USB option would not show up.

Move the cursor with the up/down key to the frame of the file list, click on OK to enter the list, move the cursor to the folder of which you want to save the file with the knob, and then click on OK. The knob but not the up/down key should be used in the list frame.

8.2 File Management

The file management is used to check, move and delete files such as image, status and track in local or USB. Select file management menu in the system, and the menu as figure 6-5 would pop up. .

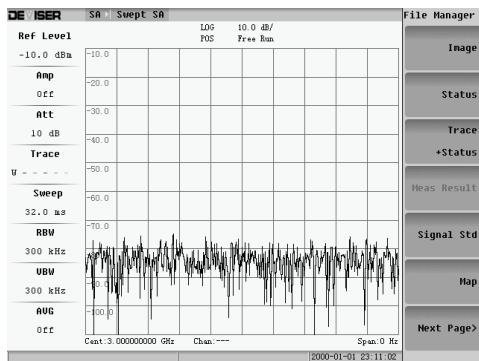

Fig. 8-5 File Management Menu

Press the corresponding soft-key to manage the file type. Select the file type to see all files of that type in the device. Move the cursor with the up/down key or the knob, and then select the file with OK. Press **Select All** to select all files. Press **Delete**, **Copy to U Disk**, **Copy to Local** or **Load in** to delete, copy or loading the file as figure 6-6.

After copying completing, it could remind it at the bottom of the pop-up dialog box.

AD8000 Series Spectrum Analyzer Instruction

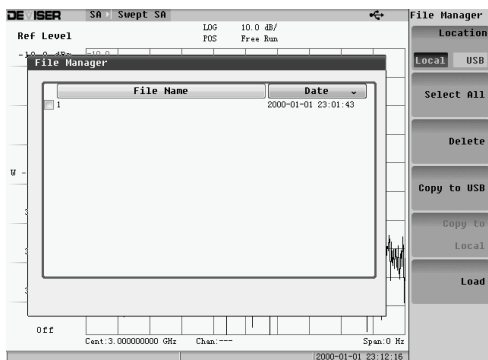

Fig. 8-6 Corresponding File Management Menu

9 Other Functions and Settings

This chapter would mainly introduce following items:

- System Calibration
- System Settings
- System Information
- Software Update
- Other Function

AD8000 Series Spectrum Analyzer Instruction

The chapter mainly introduces the system parameter and inquiring system information by pressing **SYS** key.

After pressing **SYS**, the Menu of 9-1 will pop up. Press "Next Page" the menu of 9-2 would pop up. And press "Next Page" again the menu of 9-3 would pop up.

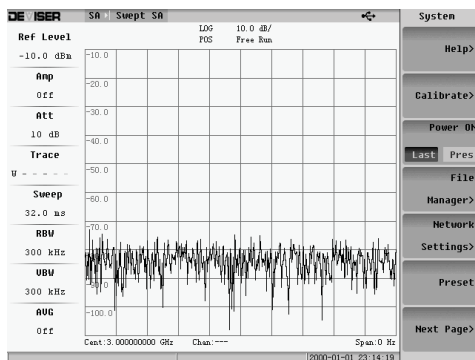

Fig. 9-1 System Menu (Page 1)

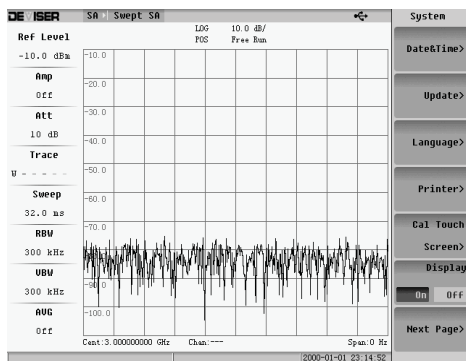

Fig. 9-2 System Menu (Page 2)

AD8000 Series Spectrum Analyzer Instruction

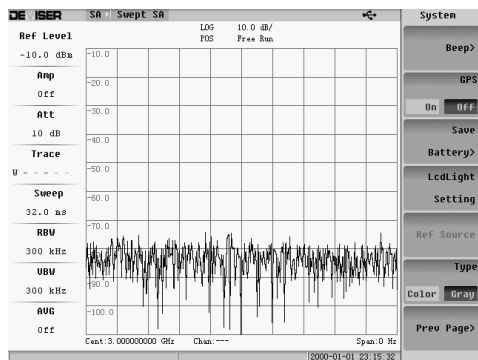

Fig. 9-3 System Menu (Page 3)

9.1 System Calibration

System calibration needs to be done frequently for the electronic measurement instrument. After a period of using, system calibration should be done. If the environment such as temperature changes dramatically, or users do not think the result reliable, system calibration also needs to be done.

System calibration includes frequency calibration and amplitude calibration. Frequency calibration is to correct the frequency error caused by IF filter which bandwidths in every IF filter should be calibrated. Amplitude calibration is more complicated. The cause for amplitude error might be reference level. Therefore, for different filter bandwidth, attenuator and reference level should both be calibrated.

To calibrate the system, please process as following steps: A

Press "CAL" soft-key in the first page of system menu, and the menu of 5-3 will pop up.

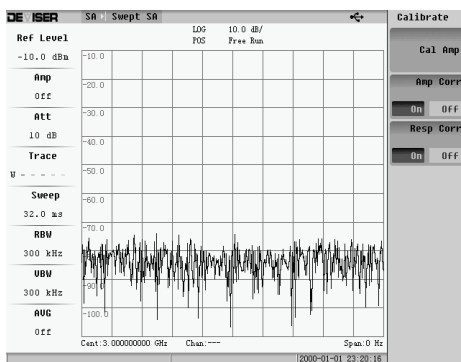

Fig. 9-4 Calibration Menu

Attention: please do not do any operation before the calibration completing.

The second and third buttons of the menu indicate 'Use/Cancel' calibration data or frequency response data separately. There two corrections could be canceled and then turned on one or both when needed. The frequency

AD8000 Series Spectrum Analyzer Instruction

data is set before the instrument is sold. Users do not need to and cannot change.

Select 'Cancel' in amplitude calibration and frequency calibration, and then a calibration cancel mark would pop up at the top of the interface shown as figure 5-4.

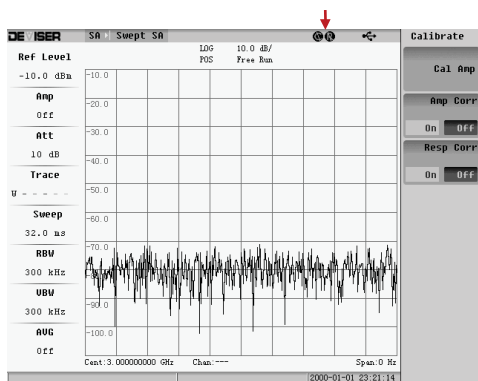

Fig. 9-5 Calibration Cancel Menu

9.2 Help Information

After pressing the soft-key 'Help', a dialog box of system information would pop up showing the system information of current instrument as figure 7-6.

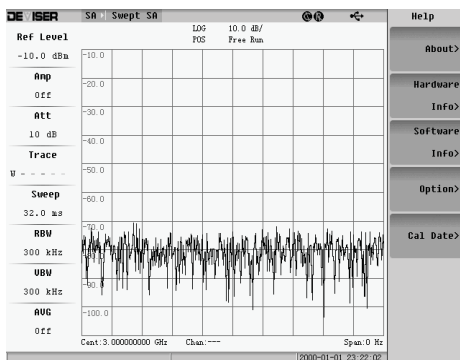

Fig. 9-6 Help Menu

The dialog box mainly contains the product series number, software and hardware version information.

Hardware information includes disk free space, dump battery, dump using time, and in-device temperature. Press OK or Return to close the dialog box.

Software information is used to check the release time of the software.

Option shows whether the device has the option or not, i.e. whether user has purchased and used the option.

Calibration date is used to check the time of frequency response update and calibration.

9.3 System Settings

It is used to set system parameters including screen display, communication, language and etc.

9.3.1 Network

AD8000 network setting function accepts remote control. Press the **Network Settings** key, and the follow menu will pop up.

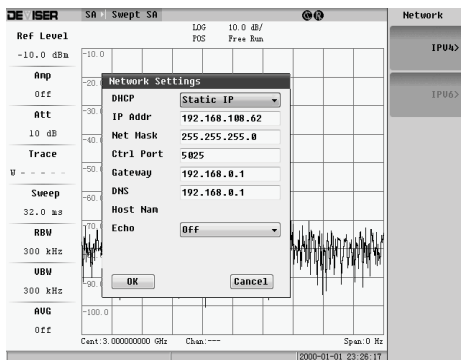

Fig. 9-7 Network Setting Menu

DHCP: Select between DHCP IP mode and Static IP mode. The default is a static IP, which can be selected through the drop-down list

IP address: IP address button in network setting, user could set the IP communication address of the instrument

Subnet Mask: use in fixed IP environment

Port Number: port number of network connections, the default is 5025

Gateway: IP address of the gateway;

DNS: IP address of DNS server;

Host Name: assigned the host name

If it dynamically obtains an IP, the follow dialog will pop up:

AD8000 Series Spectrum Analyzer Instruction

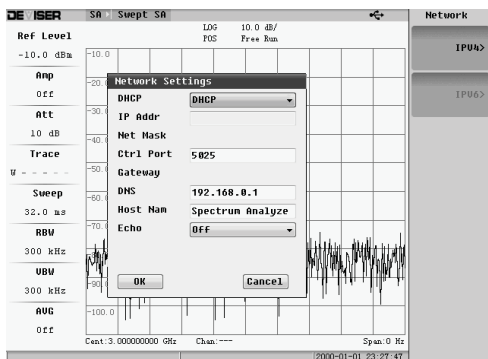

Fig. 9-8 Menu of Obtaining Dynamic IP

Users could move the blue cursor to 'OK' or 'Cancel' with the up/down key or knob. Click on 'OK' to save the setting and close the dialog box and 'Cancel' to quit without saving.

9.3.2 Language

Press the “Language Select” soft-key, and the following menu would pop up. AD8000 offers 2 languages. Select one, and then all menus would change into that language. The default is Chinese. Changing language would not cause restoration because of power-off.

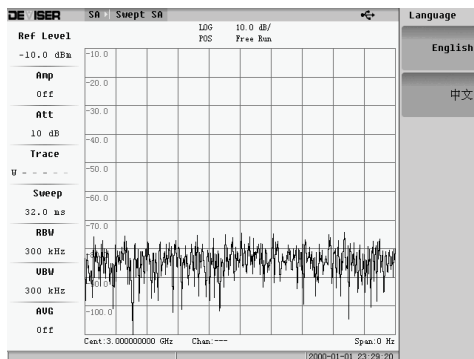

Fig. 9-9 Language Setting Menu

9.3.3 Buzzer

AD8000 has a built-in buzzer used for buzzing for faulty operation or device breakdown. Users could set the status of the buzzer. Press the "Beep Settings" soft-key, and the following menu will pop up.

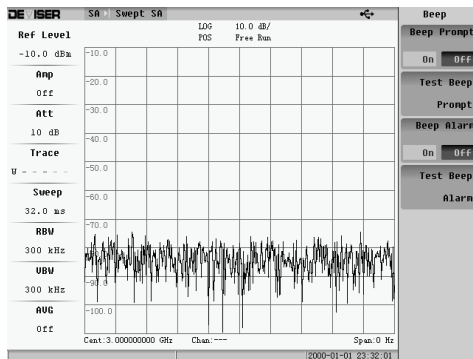

Fig. 9-10 Buzzer Setting Menu

The difference between the prompt beep and alarm beep is volume. User can test the 2 alarm functions by pressing 'Test Prompt Beep' and 'Test Alarm Beep'. Press the test function key, and buzzer will be forced to beep once no matter what status the buzzer is in.

When buzzer is turned on, there will be a corresponding voice prompt for each button. There would be an audible alarm for illegal operation or low battery with the buzzer turning on.

9.3.4 GPS

If users have purchased GPS, the status of GPS option in option dialog box is on. Users could turn it off. The operation interface is shown as below:

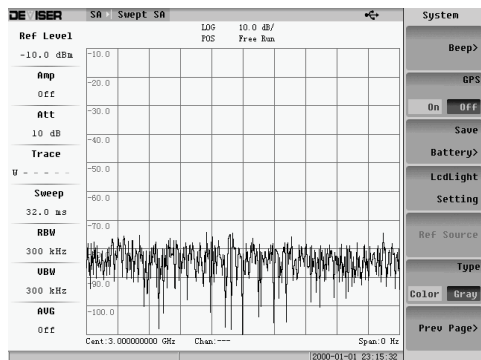

Fig. 9-11 GPS Setting

If users did not purchase GPS, the button would be gray as unavailable.

9.3.5 Time

After pressing 'Time Setting' button, the following menu which users could use to set date and time would pop up.

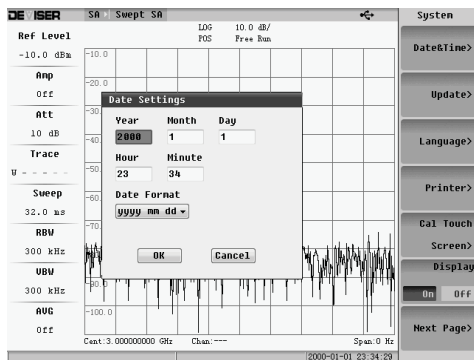

Fig. 9-12 Time Setting Menu

The blue cursor could be moved to the position of which parameter you want to edit with the up/down key and knob. Change the date and time with the number keys. The date display format could be chosen from 'YMD', 'MDY' and 'DMY' in the pull-down list. Click on 'OK' to save the setting and close the dialog box, and 'Cancel' to quit without saving.

9.4 Software Update

When you need to upgrade software, contact our company for the latest firmware. Software can only be upgraded with USB disk.

Before updating, copy update file `upd_file.dat` and `upd_ver.txt` into the root directory of the U disk. In the second page of the System Menu, select the "upgrade" soft key, and the following menu will pop up. Press 'OK' to upgrade, and press "Cancel" to return to the previous interface.

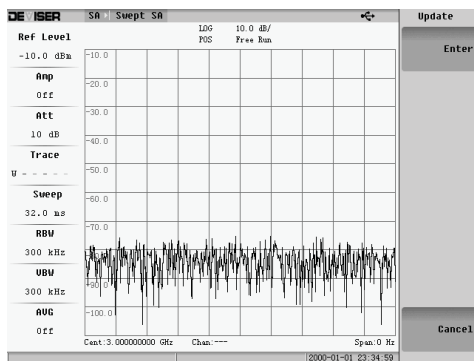

Fig. 9-13 Update Menu

It will display the graphic interface during the update procedure normally. There will be prompt if the update succeeds. If the upgrade fails, an error message with cause of failure will be displayed on the screen.

10 Program Guide

AD8000 series handheld spectrum analyzer could be control remotely with the standard net access. The WorkBench provides a integrated solution. It could control multiple devices through the network, and implement drawing wave, sending command and generating report. Most functions which could be done with the analyzer could be implemented with WorkBench.

Because of different reason, users might still need to write software to control AD8000 themselves. The purpose of this chapter is to make users be able to write control software themselves after reading it.

10.1 SCPI Basis

10.1.1 Brief Introduction

AD8000 adapts general SCPI (Standard Commands for Programmable Instruments) instruction set as control order. The advantages of using this instruction set are:

Character string format, easy to understand

Good commonality, could be used with most of instruments of other brands

Please get to know its syntax. For detailed information, please refer to:

IEEE Standard 488.1-1987, IEEE Standard Digital Interface for Programmable Instrumentation. New York, NY, 1998.

IEEE Standard 488.2-1987, IEEE Standard Codes, Formats, Protocols and Comment Commands for Use with ANSI/IEEE Std488.1-1987. New York, NY, 1998.

10.1.2 Command Keywords & Syntax

A piece of typical command is formed by some keywords separated by colon. Keywords might follow with parameter information.

Example: SENSE: FREQUENCY: START 1.5 MHZ

The command is not case sensitive. In this chapter, parts in capital letters indicate abbreviations of keywords. A keyword could be written in full name or abbreviation.

Example: Sens: Freq: Star 1.5 mhz

Example: SENSE: FREQ: start 1.5 MHz

Two commands above implement the same function.

Please pay attention of wrong writing as below: SENS:

FREQU: STAR

Because FREQU is neither keyword nor abbreviation, only full name or full abbreviation could be recognized. \

10.1.3 Create Valid Command

Since the command is not case sensitive, every command may have multiple expressions. Examples of valid command are shown below:

Command Syntax	Valid Command
[SENSe:]BANDwidth[: RESolution] <freq>	Sense: Band: Res 1700
	sens: band 1.7KHZ
	band 1.7kHz
UNIT: POWer?	Unit: Pow?
	UNIT: POW?
	uNIT: POWER?
[: SENSE]: DETector[: FUNcTion]NEGative POSitive SAMPLE	DET: FUNC neg
	Detector: Func Pos
INITiate: CONTInuous ON OFF 1 0	INIT: CONT ON
	init: continuous 1

10.1.4 Special Characters in Command

Special Characters	Meaning	Example
	A between parameters indicates alternative choices. One meaning is the parameter choices, which is to choose one from several. The effect of the command is different depending on which parameter is selected.	TRIGger[: SEQUence]: FIEld ODD EVEN ODD and EVEN are two choices For example, TRIG: FIEld ODD is one choice
	Another meaning is that a command could be expressed differently. Only one keyword could appear once in two expressions.	SENSe: BANDwidth BWIDth: OFFSet For the command above, expressions below are both right: BWIDTh: OFFSET SENSE: BAND: OFFSET
[]	Keywords in [] are omissible.	[SENSe:]BANDwidth[: RESolution]: AUTO For the command above, expressions below are both right: bandwidth: auto band: resolution: auto sense : bandwidth: auto
< >	Words in < > do not mean themselves literally. They describe parameter information	SENS: FREQ<freq> In this command, <freq> should be replaced with a real frequency value such as SENS: FREQ 9.7MHz.

10.1.5 Parameters in Command

Four basic parameter types: Boolean type, keyword, variate and binary number

Boolean type: OFF|ON|0|1

The Boolean type represents a binaryization value. 0 has is equivalent to character string OFF. 1 or any other nonzero number are equivalent to ON. It would return to ON or OFF when checking.

For example: BWIDth: VDeo: AUTO ON indicates setting VBW as valid.

Keyword:

In every specific command, there is a specific keyword. Special keywords below could also be used in some commands. But not all commands support them:

UP – increase parameter value

DOWN – decrease parameter value

Variate

The variate of value type might come with unit. The used unit depends on the variate type (describing below). If there is no unit, the system would recognize as default unit. There could be or not be space between unit and number.

Parameter	Meaning	Type	Unit	Default
<integer>	Normal Integer	Integer Value	---	---
<real>	Normal Decimal	Floating-Point Number	---	---
<freq>	Frequency	Rational Number	Hz, kHz, MHz, GHz.	Hz
<bandwidth>	Bandwidth	Positive Rational Number	Hz, kHz, MHz, GHz.	Hz
<time>	Time	Positive Rational Number	s, ms,	ns
<seconds>			us, ns	
<ampl>	Amplitude	Positive Rational	dBm, dBuV	dBm

AD8000 Series Spectrum Analyzer Instruction

Parameter	Meaning	Type	Unit	Default
		Number	dBmV, mV	
<rel_power>	Relative	Rational Number	dB	dB
<rel_ampl>				
<percent>	100%	0-100	PCT	PCT
<string>	Character String	Character String	---	---

1 Binary Number

Use <arbitrary block data> type to represent binary number. Named it 'binary number' is for distinguishing with the other 3 types. Directly sending binary number could not only increase the transmission efficiency, but also be good for programming analysis.

The binary number data starts with '#', and follows by several visible characters.

For example: start with #512320,

5 indicates that there are 5 ASCII characters behind

12320 indicates that there are 12320 binary number data behind.

10.2 Control Method

10.2.1 Connection Method

There are two ways to connect PC with AD8000. One is to connect through crossover net cable, and the other is to connect the PC and AD8000 into the same Ethernet with a direct network cable.

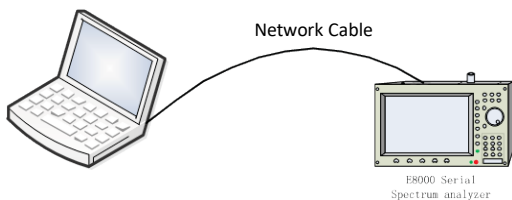

Fig. 10-1 Connecting to PC Directly

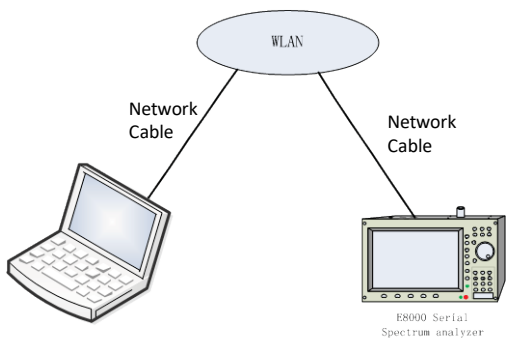

Fig. 10-2 Connecting in Ethernet

When producing the network, the order of 2 twisted pairs has been stipulated in the EIA/TIA cable distribution standard: 568B and 568A.

AD8000 Series Spectrum Analyzer Instruction

No.	568A	568B
1	Green, white	Orange, white
2	Green	Orange
3	Orange, white	Green, white
4	Blue	Blue
5	Blue, white	Blue, white
6	Orange	Green
7	Brown, white	Brown, white
8	Brown	Brown

The order of 2 ends of direction network cable is the same, which is 568A or 568B; the ends of crossover cable are 568A and 568B differently, which is that 1 and 3 interchange, and 2 and 6 interchange.

Network Cable	Crosswire
1 <----> 1	1 <----> 3
2 <----> 2	2 <----> 6
3 <----> 3	3 <----> 1
4 <----> 4	4 <----> 4
5 <----> 5	5 <----> 5
6 <----> 6	6 <----> 2
7 <----> 7	7 <----> 7
8 <----> 8	8 <----> 8

It shows the simplest connection way above. Actually, one PC could connect with multiple AD8000, and one AD8000 could also connect to multiple PCs that they could constitute a mesh topological structure.

AD8000 Series Spectrum Analyzer Instruction

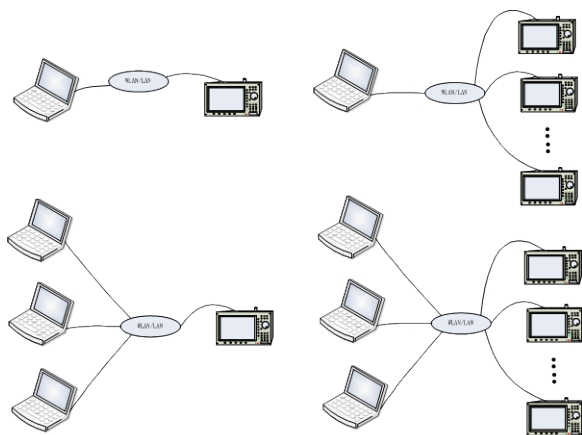

Fig. 10-3 Network Topology

10.2.2 PC Hardware Setting

Since AD8000 only supports 10M network card, before using Ethernet to control remotely, if the network card of PC is not 10M, it should be changed to 10M enforcedly. The configuration method is as below:

Right click on My Computer, select Attribute, and the dialog box of figure 10-4 would pop up.

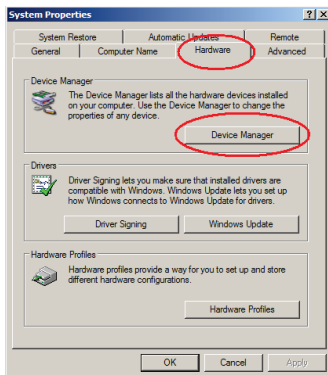

Fig. 10-4 Attribute Dialog Box

- (1) Select Hardware -> Device Manager shown in figure 10-4, and the device management dialog box as figure 10-5 would pop up.

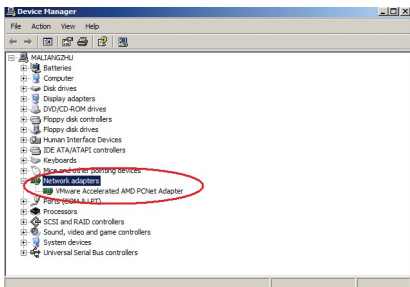

Fig. 10-5 Device Manager Dialog Box

AD8000 Series Spectrum Analyzer Instruction

- (2) Select Network Configurator -> D-Link DFE-530TX PCI Fast Ethernet Adapter(rev.c) as figure 10-5, and the network hardware configuration dialog box as figure 10-6 would pop up.

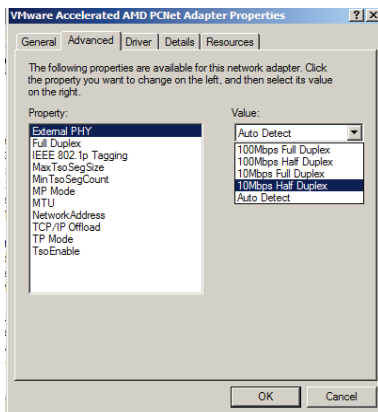

Fig. 10-6 Network Hardware Configuration Dialog Box

- (3) Select Advance -> Attribute -> Connection Type -> 10BaseT Full Duplex as figure 10-6 to set the network card as 10M.

10.3 Command Instruction

The sent & received commands end with a line feed. The corresponding binary code is 0x0d and 0x0a.

For example: send the command of getting series number *IDN?

7 characters *IDN?/0x0d/0x0a should be sent practically.

In the command, it has returned value with '?', otherwise, it is control statement.

The standard SOCKET communication could be used in programming. Pay attention in some large data volume transmission, such as TRACe?. Get the current wave data, return to float type data of 421 points, and it is 1692 characters in total with file header #42004 and end-of-file 0x0d 0x0a. Generally MTU (maximum transmission unit) is set as 1500 characters in network transmission. At the moment the data would be divided into 2 packs. Programmers should consider the problem of combining packs.

10.3.1 General Command

Command	Meaning	Input/Output
*RST	Software restoration	---
*IDN? <string>	Getting series No.	Character string
*OPT	Options information	---

Example 1: read series number

Command: *IDN?

Returned value: spectrum analyzer, AD INSTRUMENTS

Indicate device name, company, series number, and version

Attention: the returned value here is only measurement value. It does not indicate that it is the same to users, same for following.

10.3.2 System Command

Command	Meaning	Input/Output
UPGRade	Upgrade	---
DISPlay:ENABLE<Boolean>	Set LCD EN	ON OFF
DISPlay:ENABLE	Read LCDEN	ON OFF

10.3.3 Spectrum Analysis Mode Command List

10.3.3.1 Wave

Command	Meaning	Input/Output
TRACe:[DATA	Read wave	Wave data of corresponding points

10.3.3.2 Frequency

Command	Meaning	Input/Output
[SENSe:]FREQUENCY: CENTer <freq>	Set center frequency	Frequency value
[SENSe:]FREQUENCY: CENTer?	Read center frequency	Frequency value
[SENSe:]FREQUENCY: START <freq>	Set start frequency	Frequency value
[SENSe:]FREQUENCY: START?	Read start frequency	Frequency value
[SENSe:]FREQUENCY: STOP <freq>	Set end frequency	Frequency value
[SENSe:]FREQUENCY: STOP?	Read end frequency	Frequency value
[SENSe:]FREQUENCY: SPAN <freq>	Set bandwidth	Frequency value
[SENSe:]FREQUENCY: SPAN?	Read bandwidth	Frequency value
[SENSe:]FREQUENCY: SPAN: FULL	Set full-band sweep	---
[SENSe :]FREQUENCY : SPAN : PREVIOUS	Previous sweep	---
[SENSe:]FREQUENCY: CENTer: STEP <freq>	Set center frequency step	Frequency value

AD8000 Series Spectrum Analyzer Instruction

[SENSe :]FREQUency : CENTer : STEP?	Read center frequency step	Frequency value
[SENSe :]FREQUency : CENTer : STEP: AUTO <Boolean>	Set frequency step auto or not	ON OFF Auto Manual
[SENSe :]FREQUency : CENTer : STEP: AUTO?	Read frequency step auto or not	ON OFF Auto Manual

Example 1: set the center frequency as 300.33 MHz

Command: FREQ: CENT 300.33 MHz

Example 2: read whether the frequency step is auto or not

Command: FREQUency: CENTer: STEP: AUTO?

Returned value: ON

Indicates auto

10.3.3.3 Amplitude

Command	Meaning	Input/Output
DISPlay : WINDow : TRACe : Y[: SCALE]: RLEVel <ampl>	Set reference level	Amplitude value
DISPlay : WINDow : TRACe : Y[: SCALE]: RLEVel?	Read reference level	Amplitude value
UNIT : POWER DBM DBMV DBUV V MV UV NV	Set unit of reference level	Character string
UNIT: POWER?	Read unit of reference level	Character string
[: SENSe]: POWER[: RF]: ATTenuation <rel_ampl >	Set attenuator value	dB value
[: SENSe] : POWER[: RF] : ATTenuation?	Read attenuator value	dB value
[: SENSe] : POWER[: RF] : ATTenuation: AUTO <Boolean>	Set attenuator auto or not	ON OFF Auto Manual
[: SENSe] : POWER[: RF] : ATTenuation: AUTO?	Read attenuator auto or not	ON OFF Auto Manual
[: SENSe]: POWER[: RF]: GAIN[:	Set pre-amplifier	ON OFF

AD8000 Series Spectrum Analyzer Instruction

Command	Meaning	Input/Output
STATe] <Boolean>	on/off status	
[: SENSE]: POWer[: RF]: GAIN[: STATe]?	Read pre-amplifier on/off status	ON OFF
DISPlay : WINDow : TRACe : Y[: SCALE]: SPACing LOGarithmic LINear	Set scale as linear or log	Character string
DISPlay : WINDow : TRACe : Y[: SCALE]: SPACing?	Read scale as linear or log	Character string
DISPlay : WINDow : TRACe : Y[: SCALE]: PDIVision < real >	Set unit/div	Unit/div
DISPlay : WINDow : TRACe : Y[: SCALE]: PDIVision?	Read unit/div	Unit/div
DISPlay : WINDow : TRACe : Y : [SCALE] : RLEVel : OFFSet : STATe <Boolean>	Set referece level on/off	ON OFF
DISPlay : WINDow : TRACe : Y : [SCALE]: RLEVel: OFFSet: STATe?	Read level off-set on/off	ON OFF
DISPlay : WINDow : TRACe : Y : [SCALE]: RLEVel: OFFSet <rel_ampl >	Set reference level off-set	dB value
DISPlay : WINDow : TRACe : Y : [SCALE]: RLEVel: OFFSet?	Read reference level value	dB value

AD8000 Series Spectrum Analyzer Instruction

Example 1: set reference level as 73.6 dBuV

Command: DISP: WIND: TRAC: Y: RLEV 73.6 dBuV

Example 2: set it as linear mode

Command: DISP: WIND: TRAC: Y: SPAC LOG

Example 3: read attenuator

Command: POW: ATT?

Returned value: 10

It indicates that current attenuator is 10 dB.

10.3.3.4 CPL

Command	Meaning	Input/Output
[SENSe :]BANDwidth BWIDth[: RESolution]<bandwidth>	Set RBW	Bandwidth value
[SENSe :]BANDwidth BWIDth[: RESolution]?	Read RBW	Bandwidth value
[SENSe :]BANDwidth BWIDth[: RESolution]: AUTO <Boolean>	Set RBW auto or not	ON OFF Auto Manual
[SENSe :]BANDwidth BWIDth[: RESolution]: AUTO?	Read RBW auto or not	ON OFF Auto Manual
[SENSe :]BANDwidth BWIDth : VIDEo <freq>	Set VBW	Bandwidth value
[SENSe :]BANDwidth BWIDth : VIDEo?	Read VBW	Bandwidth value
[SENSe :]BANDwidth BWIDth : VIDEo: AUTO <Boolean>	Set VBW auto or not	ON OFF Auto Manual
[SENSe :]BANDwidth BWIDth : VIDEo: AUTO?	Read VBW auto or not	ON OFF Auto Manual
[SENSe:]SWEep: TIME <seconds >	Set sweep time	Time value
[SENSe:]SWEep: TIME?	Read sweep time	Time value
[SENSe :]SWEep : TIME : AUTO <Boolean>	Set sweep time auto or not	ON OFF Auto Manual
[SENSe:]SWEep: TIME: AUTO?	Read sweep time auto or not	ON OFF Auto Manual
INITiate: CONTinuous <Boolean>	Set single sweep or not	ON OFF Continuous single
INITiate: CONTinuous?	Read single sweep or not	ON OFF Continuous single
[SENSe :]AVERage[: STATE] <Boolean>	Set video average on/off	ON OFF
[SENSe:]AVERage[: STATE]?	Read video average on/off	ON OFF
[SENSe:]AVERage: : STATE:COUNT	Set video	Average Times

AD8000 Series Spectrum Analyzer Instruction

Command	Meaning	Input/Output
<integer>	average times	
[SENSe:]AVERAge: STATE:COUNT?	Read video average times	Average Times
[SENSe :]AVERAge : CLEAr < Boolean >	Set video average times re-count	Average Times
[SENSe:]AVERAge: CLEAr?	Read video average times re-count	Average Times
COUPlE ALL NONE	Set full auto or not	ALL NONE Full-auto non-auto
COUPlE?	Read full auto or not	ALL NONE Full-auto non-auto
SPECTrum: CAPTure <Boolean>	Set fast sweep mode on/off	ON OFF Fast normal sweep
SPECTrum: CAPTure?	Read spectrum capture mode on/off	ON OFF Fast normal sweep

AD8000 Series Spectrum Analyzer Instruction

Example 1: Set RBW as 300 KHz

Command: BWIDth 300 KHz

Example 2: Read current sweep time

Command: SWEEP: TIME?

Returned value: 20000000

It indicates that current sweep time is 20 ms

Example 3: Set sweep time as 1.5s

Command: SWEEP: TIME 1.5s

Example 4: Read video average on or off

Command: AVER?

Returned value: OFF

It indicates that the average is off

Example 5: Set RBW, VBW and sweep time as auto

Command: COUPLE ALL

10.3.3.5 Detection Mode & Trigger Mode

Command	Meaning	Input/Output
[SENSe:]DETEctor[: FUNCtion] POSitive NEGative SAMPle AVER age NORMAL	Set detection mode	POSitive NEGative SAMPle AVERage NORMAL
[SENSe :]DETEctor[: FUNCtion]?	Read detection mode	POSitive NEGative SAMPle AVERage NORMAL
TRIGger[: SEQuence]: SOURce IMMEDIATE VIDEO LINE	Set trigger mode	IMMEDIATE VIDEO LINE
TRIGger[: SEQuence] : SOURce?	Read trigger mode	IMMEDIATE VIDEO LINE
TRIGger[: SEQuence]: VIDEO: LEVEL < percent >	Set percentage of video trigger level	Percentage
TRIGger[: SEQuence]: VIDEO: LEVEL?	Read percentage of video trigger level	Percentage
TRIGger[: SEQuence] : SLOPe POSitive NEGative	Set video trigger mode	POSitive NEGative
TRIGger[: SEQuence]: SLOPe?	Read video trigger mode	POSitive NEGative
TRIGger[: SEQuence] : STANDARD PAL NTSC	Set line trigger system	PAL NTSC
TRIGger[: SEQuence] : STANDARD?	Read line trigger system	PAL NTSC
TRIGger[: SEQuence] : FIEld ODD EVEN	Set line trigger field	ODD EVEN
TRIGger[: SEQuence]: FIEld?	Read line trigger field	ODD EVEN

Example 1: Set detection mode as sample detection

Command: DETECTOR[: FUNCTION] SAMPL

Example 2: Read current trigger mode

Command: TRIGGER[: SEQUENCE]: SOURCE?

AD8000 Series Spectrum Analyzer Instruction

Returned level: IMMEDIATE

It indicates that the current trigger mode is free trigger

Attention: To set trigger line, it must be line trigger mode, otherwise the sentence is invalid. If the similar upper level word (for example TRIGGER) is not set, current setting (LINE) might be invalid. Following is the same.

10.3.3.6 Frequency Mark

Command	Meaning	Input/Output
CALCulate : MARKer : STATE <Boolean>	Set general mark on/off	ON OFF
CALCulate : MARKer : STATE?	Read general mark on/off	ON OFF
CALCulate : MARKer : MODE POSITION DELTA OFF	Set mark type	Normal Delta OFF
CALCulate : MARKer : MODE?	Read mark type	POSITION DELTA OFF
CALCulate : MARKer : MAXimum?	Read peak value	Amplitude value
CALCulate : MARKer : MINimum?	Read min. value	Amplitude value
CALCulate : MARKer : PTPeak?	Read peak-peak value	Amplitude value
CALCulate : MARKer : CPEak: STATE <Boolean>	Set peak tracking on/off	ON OFF
CALCulate : MARKer:CPEak:STATE?	Read peak tracking on/off	ON OFF
CALCulate : MARKer : FCOunt[STATE]<Boolean>	Set frequency count on/off	ON OFF
CALCulate : MARKer : FCOunt[: STATE]?	Read frequency count on/off	ON OFF
CALCulate: MARKer: X <freq>	Set frequency mark	Frequency value
CALCulate : MARKer : X?	Read frequency mark	Frequency value
CALCulate : MARKer : Y?	Read mark amplitude	<ampl> unit is same as reference level

AD8000 Series Spectrum Analyzer Instruction

Example 1: turn on general mark

Command: CALCulate: MARKer: STATe ON

Example 2: find out peak value

Command: CALCulate: MARKer: MAXimum

Example 3: Read amplitude of current mark

Command: CALCulate: MARKer: Y?

Returned value: 80.83

It indicates that the level is 80.83 dBuV (when current reference level is dBuV)

10.3.3.7 NdB Function

Command	Meaning	Input/Output
CALCulate: BANDwidth: STATE<Boolean>	Set NDB measurement on/off	ON OFF
CALCulate: BANDwidth: STATE?	Read NDB measurement on/off	ON OFF
CALCulate: BWIDth: STATE<Boolean>	Reload NDB measurement on/off	ON OFF
CALCulate: BWIDth: STATE?	Read reloaded NDB measurement on/off	ON OFF
CALCulate: BANDwidth: NDB<rel_amp>	Set NdB value	<rel_amp> unit dB
CALCulate: BANDwidth: NDB?	Read NdB value	<rel_amp> unit dB
CALCulate: BWIDth: NDB<rel_amp>	Reload Set NdB value	<rel_amp> unit dB
CALCulate: BWIDth: NDB?	Read reloaded NdB value	<rel_amp> unit dB
CALCulate: BANDwidth: RESult?	Read NdB measurement result	Frequency value
CALCulate: BWIDth: RESult?	Read reloaded NdB measurement result	Frequency value

Example 1: enabled NdB measurement

Command: CALCulate: BANDwidth: STATE ON

Example 2: Read NdB measurement result

Command: CALCulate: BANDwidth: RESult?

Returned value: 58KHz

It indicates that the NdB measurement result is 58KHz

Indicate 33.3 dBmV / Hz

11 Appendix

11.1 Glossary explanation

AI	Amplitude Imbalance
AM	Amplitude Modulation
BW	Bandwidth
BER	Bit Error Rate
CCN	Carrier-to-noise ration
CSO	Composite Sencond-Command Beat
CTB	Composite Triple Beat
dB	Decibel
DVB	Digital Video Broadcasting
DVB-C	Digital Video Broadcasting baseline system for digital cable television (ETS 300 429 [6])
DVB-S	Digital Video Broadcasting baseline system for digital satellite television (ETS 300 421 [5])
DVB-T	Digital Video Broadcasting baseline system for digital terrestrial television (ETS 300 744 [9])
EQ	Equalizer
ENB	Equivalent Noise Bandwidth
EB	Errored Block
ES	Errored Second
EVM	Error Vector Magnitude
ENM	Estimate Noise Margin

AD8000 Series Spectrum Analyzer Instruction

PAL	Phase Alternating Line
PJ	Phase Jitter
QAM	Quadrature Amplitude Modulation
QPSK	Quaternary Phase Shift Keying
RF	Radio Frequency
RBW	Resolution Bandwidth
SES	Seriously Errored Second
TJ	Time Jitter
TS	Transport Stream
USB	Upper Bandwidth

11.2 Prompt Information List

No.	Prompt Info.	Source/cause	Solution
101	Option has not been installed.	Using some uninstalled function.	Install the option.
102	Low battery. Please charge.	Adaptor is not inserted when updating.	Insert the adaptor.
103	Incomplete update file	The update file is incorrect.	Prepare correct update software.
104	Please shut dwn and restart.	Power-off needs to be done after updating.	Shut down and restart.
105	Mismatching series No.	The series number of updating option information is unauthorized.	Purchase the option
106	Not yet 15min after booting	The preheating time of frequency response is not enough.	Boot for over 15min.
107	Please select spectrum analysis mode.	Dual-window is turned on, or it is not in spectrum analysis mode.	Turn off dual-window, and enter spectrum analysis mode.
201	Saving image	The system is saving image.	Wait for several second.
202	File exists. Want to cover?	The saving file has existed.	Press ENTER to cover, and ESC to cancel.
203	File does not exist	The using file does not exist.	Confirm file
204	Want to delete?	Confirmation of deleting file.	Press ENTER to delete, and ESC to cancel.
205	File transfer completes.	File transfer completes.	---
206	File transfer fails.	File transfer fails.	Check the port.

AD8000 Series Spectrum Analyzer Instruction

207	File saving completes	File saving completes	---
208	Please enter file name, and press ENTER to continue.	File name needs to be entered when saving file.	Press ENTER after inputting in numbers.
209	Insufficient disk space.	When saving new file.	Delete some redundant files.
210	Insufficient U disk space	Copy file to U disk or update	Clear U disk
211	No U disk found	When data needs to be exchanged with U disk	Insert in U disk
212	Network connection fails.	When connecting to the network port	Check network setting
213	Serial port connection fails.	When connecting with serial port	Check serial port line and baud rate.
214	Please select file	No file is selected before operation	Select at least one file.
215	Deleting succeeds.	Deleting succeeds.	---
216	Deleting fails.	The file is being used.	Make is inactive.
217	Network time-out	Network connection time-out	Check network connection.
220	Disconnected printer	Does not connect to the printer	Check printer configuration.
301	Span could not be 0	Some measurement need non-zero span.	Set the span to non-zero.
302	RBW too small	RBW<3KHz in frequency count	Set RBW>=3KHz
303	Turn off frequency count	It is counting when measuring	Turn off frequency count
304	Please turn off peak list.	The peak list is on when measuring	Turn off peak list
305	Calibration succeeds.	The instrument calibration succeeds	---
306	Calibration fails.	Calibration fails.	Check signal input.
307	Turn off line trigger	It is line trigger	Change the trigger

AD8000 Series Spectrum Analyzer Instruction

		before measuring	to line trigger
308	Turn off FM	It is FM mode before measuring	Demodulate to AM
309	Please turn off dual-window.	It is dual-window mode before measuring	Turn off dual-window function.
310	Please switch to log	It is linear mode before measuring	Switch to log mode.
311	Please turn off level offset.	The level offset is on before measuring	Turn off level offset.
312	Please turn off reference line.	The reference line is on before measuring	Turn off reference line.
313	Please turn on reference line.	The reference line is off before comparing.	Turn on reference line.
314	Signal source not found.	The signal source is not connected when Frequency Response correction	Connect to specified signal source
401	Please turn of channel measurement	The channel measurement is on before measuring	Turn of channel measurement
402	Channel bandwidth setting unreasonable	Bandwidth setting too large or too small	Change the set bandwidth
403	Today recording file is full.	More than 100 records are saved one day.	Delete unnecessary records.

11.3 Specifications

All parameters in AD8000 series analyzer specification information applies for measurement of instrument storing in working temperature for more than 2 hours, preheating 10 minutes after calibration.

11.3.1 Frequency Index

Model	AD8000A	AD8400A	AD8600A
Frequency Range	9kHz~3000MHz	9kHz~4000MHz	9kHz~6000MHz
Frequency Parameters			
Aging Speed	$<\pm 1 \times 10^{-6}/\text{year}$		
Temperature Stability	$<\pm 0.5 \times 10^{-6} (0 - 50)^\circ\text{C}$		
Frequency Count Accuracy	(SNR=25 dB, resolution bandwidth (RBW) /span= 0.01)		
Calculation Accuracy	$\pm 1 \times 10^{-6} \pm 1$		
Resolution	1Hz		
Frequency Sweep Span			
0 Span	Support		
Span Range	1KHz-3000MHz	1KHz-4000MHz	1KHz-6000MHz
Sweep Time & Trigger Mode			
Sweep Time Range	20ms~250s(frequency span \geq 200Hz) 10 μ s~1000s(frequency span =0Hz) 1ms~250s(frequency span, fast sweep mode)		
Time Accuracy	$<\pm 0.2\%$		
Trigger Mode	Free, single, video, line		
Resolution Bandwidth			
Range	1Hz - 3MHz abt. 10% step		

AD8000 Series Spectrum Analyzer Instruction

Bandwidth Accuracy	<±10%	
selectivity	(60dB/3dBBWR) : <5 : 1	
Video Bandwidth		
Range	1Hz - 3 MHz abt. 10% step	
Stability		
Phase Noise (Center 1GHz)	Typical < -108 dBc/Hz @continuous signal offset 100kHz Typical < -95 dBc/Hz @ continuous signal offset 10 kHz	Typical < -105dBc/Hz @ continuous signal offset 100 kHz Typical < -100 dBc/Hz @ continuous signal offset 10 kHz

11.3.2 Amplitude Index

Model	AD8000A	AD8400A	AD8600A
Attenuator			
Range	0dB - 55dB		
Step	5dB/(1dB option)		
Built-in Amplifier			
Frequency Range	1MHz–3000MHz	1MHz-4000MHz	1MHz–6000MHz
Gain	18dB (Typical)	25dB (Typical)	
Noise Factor	4dB (Typical)		
Max. Safty Input Level	+30dBm (peak power /entrance attenuation >15dB)		
	50VDC		
TOI	Typical >15dBm	Typical > 12dBm	
Dynamic Range	>100dB		

AD8000 Series Spectrum Analyzer Instruction

Display average noise level: (AD8000A no signal input, 0dB attenuation, 100Hz RBW, 100Hz VBW, sample detection) (AD8400A/AD8600A: no signal input, 0dB attenuation, 100Hz RBW, 100Hz VBW, sample detection)			
Amplifier OFF	$\leq -125\text{dBm}$, 5MHz~1GHz $\leq -120\text{dBm}$, 1GHz~3.1GHz	$\leq -128\text{dBm}$, 2MHz~1GHz $\leq -122\text{dBm}$, 1GHz~3GHz $\leq -125\text{dBm}$, 3GHz~4.4GHz	$\leq -128\text{dBm}$, 2MHz~1GHz $\leq -122\text{dBm}$, 1GHz~3GHz $\leq -118\text{dBm}$ 3GHz~6GHz
Amplifier ON	$\leq -140\text{dBm}$, 5 MHz~1GHz $\leq -136\text{dBm}$, 1GHz~3.1GHz	$\leq -142\text{dBm}$, 10 MHz~1GHz $\leq -138\text{dBm}$, 1GHz~3GHz $\leq -135\text{dBm}$, 3GHz~4.4GHz	$\leq -142\text{dBm}$, 10 MHz~1GHz $\leq -138\text{dBm}$, 1GHz~3GHz $\leq -135\text{dBm}$, 3GHz~6GHz
Spurious Signal Response Range			
Second Harmonics	$< -70\text{ dBc} -20\text{dBm}$ MONO Mixer input, amplifier OFF	$< -70\text{ dBc} -20\text{dBm}$ MONO Mixer input, amplifier OFF	
Residual Response	(No signal input, attenuator 0)		
	$\leq -85\text{dBm}$ 5MHz-3000MHz	$\leq -80\text{dBm}$ 1MHz-4000MHz	$\leq -80\text{dBm}$ 1MHz-6000MHz
Display Range			
Log Scale	0.1 -0.9 dB/div, 0.1dB step		
	1-40dB/div, 1dB step		
Linear Scale	10div		
Scale Unit	dBm, dBmV, dB μ V, mV		
Mark Reading	0.03 dB in log		

AD8000 Series Spectrum Analyzer Instruction

Resolution	0.03% linear of reference level	
Track	3 tracks output	
Detection Mode	Sample, posi-peak, neg-peak, normal, average	
Mark Function	Peak, next peak, mark-to-center, mark-to-reference, and etc.	
Mark Display	Normal, delta, fix, frequency count	
Reference Level	-130dBm— +30dBm	
Level Accuracy	Typical $\leq\pm 0.5\text{dB}@+25\pm 5^{\circ}\text{C}$	Typical $\leq\pm 1.0\text{dB}@+25\pm 5^{\circ}\text{C}$
Resolution Bandwidth Switching Accuracy	Typical $< \pm 0.1\text{dB}$	
Input Attenuator Switching Accuracy	Typical $< \pm 0.3\text{dB}$	

AD8400A/AD8600A Basestation Analysis Index

Model	AD8400A	AD8600A
LTE Measurement Index		
LTE Frequency Range	10MHz~4.0GHz	10MHz~6GHz
Measurement Bandwidth	1.4MHz/3MHz/5MHz/10MHz/15MHz/20MHz	
EVM Mode	PDSCH, PBCH	
Measurement Report	Support	
LTE Power Measurement		
TDD-LTE Accuracy	±1.0dBTypical (input amplitude range -30dBm~+10dBm)	
FDD-LTEAccuracy	±1.0dBTypical (input amplitude range -50dBm~+10dBm)	
Modulation Quality Measurement		
Frequency Offset	±10Hz + clock standard deviation	
EVM (rms) Error (TDD)	2.0%	
EVM (rms) Error (FDD)	2.0%	
OTA Measurement		
Scanner	1. Catch 6 strongest signals; 2. Auto save; SS power and modulation quality result with GPS information	
Auto Save	1. scanner: record 3 strongest signals; 2. reference signal power; record the strongest signal	
Map Coverage	Map coverage: the S-SS power of the strongest signal, RSRP, RSRQ/ SINR, display Cell ID; Scanner: value of the strongest signal	

11.3.3 Input/Output Index

Model	AD8000A	AD8400A	AD8600A
RF Input			
Input Port	N type		
Input Impedance	50Ω		
VSWR	Typical<1.8 (10MHz ~3000MHz Attenuator≥10dB)	Typical<1.8 (10MHz– 3000MHz, Attenuator≥10dB) Typical<2.0 3000MHz –4000MHz, Attenuator≥10dB)	Typical<1.8 (10MHz– 3000MHz, Attenuator≥10dB) Typical<2.0 (3000MHz – 6000MHz Attenuator≥10dB)
Tracking Source (Option)			
Output Port	N type		
Output Impedance	50Ω		
VSWR	<2.0		
Frequency Range	100kHz-3000MHz	25MHz~4000MHz	25MHz~6000MHz
Frequency Stability	±2ppm		
Level Range	-30dBm~0dBm		
Level Step	1dB		
Harmonic Spurious	-20dBc		
Level Accuracy	±1.5dB	±2dB@20°C	
Anharmonic Spurious	-30dBc		

AD8000 Series Spectrum Analyzer Instruction

USB Output	1 USB 2.0, 1 mini USB
LAN	10M/100M self-adaption

11.3.4 Level Index

Model	AD8000A	AD8400A	AD8600A
Battery Type	Chargeable lithium battery 11.1V/5.2Ah		
Adaptor	19V/3.42A		
Charging Time	>4.5h		
Power Supplied Time	>3.5h (without track source) >2.5h (with track source)	>3h (without track source) >2.5h (with track source)	

11.3.5 Other Index

Working Temperature	-10°C - +55°C	
Storage Temperature	-40°C - +80°C	
Size (W x H x L)	257mm × 75mm × 185mm	
Net Weight (with Battery)	Abt. 2.2kg	Abt. 2.5kg
display	16cm (6.5 inches) TFT color LCD	
Display Resolution	640 × 480 pixel	

